

.....

# **FA168C-GP** **Security System**

## **Installation and Setup Guide**

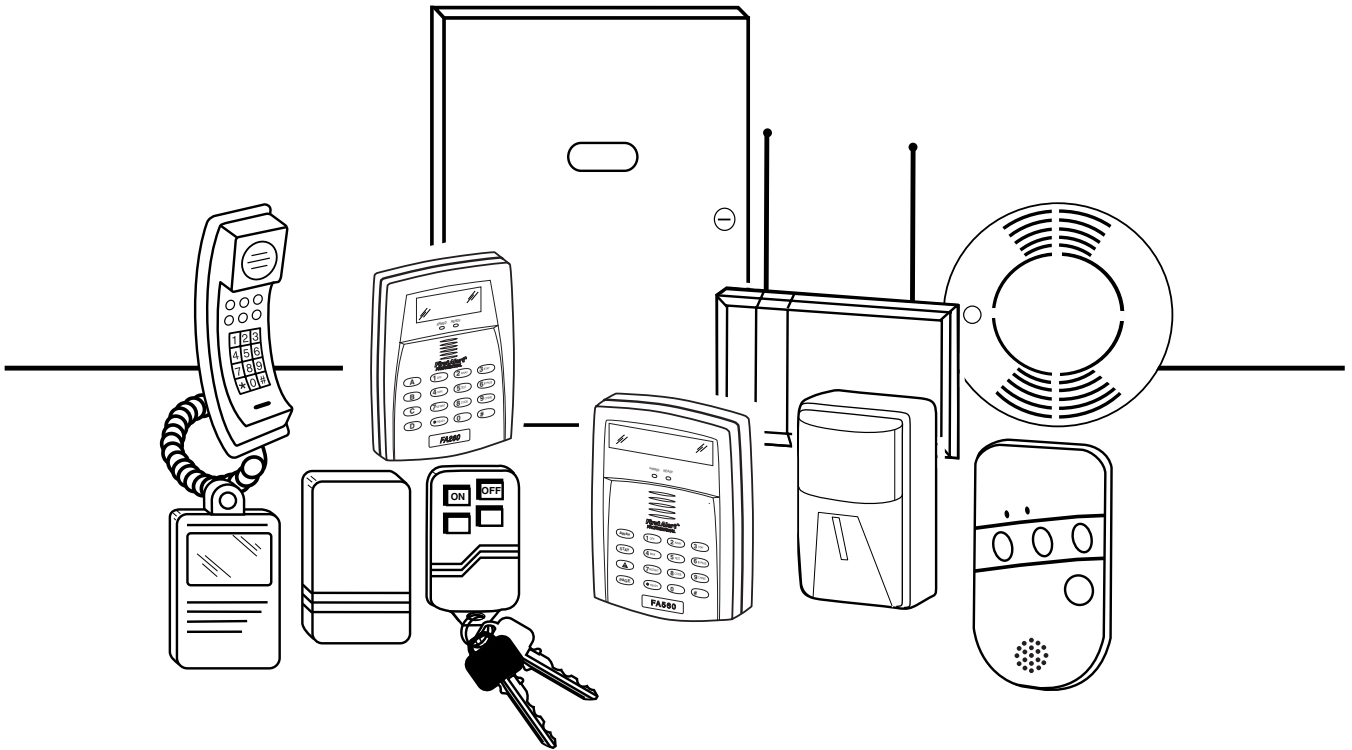

# RECOMMENDATIONS FOR PROPER PROTECTION

## The Following Recommendations for the Location of Fire and Burglary Detection Devices Help Provide Proper Coverage for the Protected Premises.

### Recommendations For Smoke And Heat Detectors

With regard to the number and placement of smoke/heat detectors, we subscribe to the recommendations contained in the National Fire Protection Association's (NFPA) Standard #72 noted below.

Early warning fire detection is best achieved by the installation of fire detection equipment in all rooms and areas of the household as follows: For minimum protection a smoke detector should be installed outside of each separate sleeping area, and on each additional floor of a multi-floor family living unit, including basements. *The installation of smoke detectors in kitchens, attics (finished or unfinished), or in garages is not normally recommended.*

For additional protection the NFPA recommends that you install heat or smoke detectors in the living room, dining room, bedroom(s), kitchen, hallway(s), attic, furnace room, utility and storage rooms, basements and attached garages.

In addition, we recommend the following:

- Install a smoke detector inside every bedroom where a smoker sleeps.
- Install a smoke detector inside every bedroom where someone sleeps with the door partly or completely closed. Smoke could be blocked by the closed door. Also, an alarm in the hallway outside may not wake up the sleeper if the door is closed.
- Install a smoke detector inside bedrooms where electrical appliances (such as portable heaters, air conditioners or humidifiers) are used.
- Install a smoke detector at both ends of a hallway if the hallway is more than 40 feet (12 meters) long.
- Install smoke detectors in any room where an alarm control is located, or in any room where alarm control connections to an AC source or phone lines are made. If detectors are not so located, a fire within the room could prevent the control from reporting a fire or an intrusion.

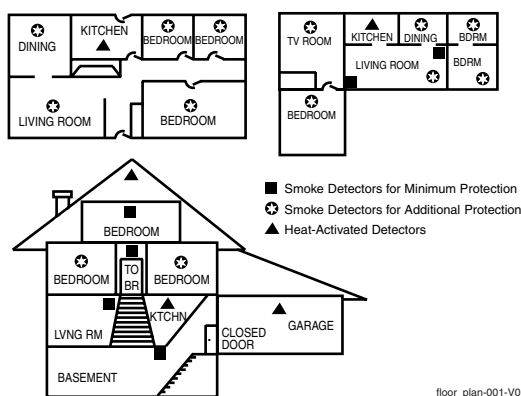

**THIS CONTROL COMPLIES WITH NFPA REQUIREMENTS FOR TEMPORAL PULSE SOUNDING OF FIRE NOTIFICATION APPLIANCES.**

### Recommendations For Proper Intrusion Protection

For proper intrusion coverage, sensors should be located at every possible point of entry to a home or commercial premises. This would include any skylights that may be present, and the upper windows in a multi-level building.

In addition, we recommend that radio backup be used in a security system so that alarm signals can still be sent to the alarm monitoring station in the event that the telephone lines are out of order (alarm signals are normally sent over the phone lines, if connected to an alarm monitoring station).

# Table Of Contents

.....

<b>Section 1. Features and Installation Highlights.....</b>	<b>1-1</b>
Capabilities.....	1-1
Functions.....	1-1
Compatible Devices.....	1-2
Important Installation Highlights (Installer Please Read).....	1-2
<b>Section 2. Mounting and Wiring the Control.....</b>	<b>2-1</b>
Cabinet and Lock.....	2-1
Mounting the PC Board Alone.....	2-1
Mounting Board with RF Receiver.....	2-2
Wiring to Keypads.....	2-3
Sounder (Bell) Connections.....	2-4
Wiring the AC Transformer.....	2-4
Backup Battery.....	2-5
Earth Ground.....	2-5
Hardwire Zones.....	2-6
Double Balanced Zones.....	2-6
Zone Doubling:.....	2-6
Smoke Detectors.....	2-6
4219/4229 Expansion Zones.....	2-8
Installing the RF Receiver.....	2-9
Installing a 5800TM Module.....	2-9
Installing the Transmitters.....	2-9
Installing a Keyswitch.....	2-10
Connecting Relay Modules.....	2-11
Powerline Carrier Devices.....	2-12
On-Board Triggers.....	2-13
Phone Line/Phone Module Connections.....	2-14
Long Range Radio Connections.....	2-15
AAV Connections.....	2-15
<b>Section 3. Programming Overview.....</b>	<b>3-1</b>
About Programming.....	3-1
Zones and Partitions.....	3-1
Keypads.....	3-2
Wireless Receiver and Transmitters.....	3-2
Pager Programming.....	3-2
Function Keys.....	3-3
Output Devices.....	3-3
Zone Type Definitions.....	3-3
Mechanics of Programming.....	3-5
<b>Section 4. Data Field Programming.....</b>	<b>4-1</b>
About Data Field Programming.....	4-1
Programming Data Fields.....	4-1
System Setup Fields (*20 – *29).....	4-1
Zone Sounds & Timing (*31–*39).....	4-2
Dialer Programming (*40 – *50).....	4-3
System Status Report Codes (*59–*68).....	4-4
Miscellaneous System Fields.....	4-6
Pager Programming Fields.....	4-8
Miscellaneous System Fields.....	4-10
Configurable Zone Type Programming Fields.....	4-11
Keypad Programming Fields.....	4-13

<b>Section 5. Zone Programming .....</b>	<b>5-1</b>
About Zone Programming.....	5-1
*56 Zone Programming Procedure .....	5-1
Completing Zone Programming.....	5-4
*58 Expert Programming Mode Procedures .....	5-4
Wireless Key Programming Templates.....	5-6
<b>Section 6. Output Device Programming .....</b>	<b>6-1</b>
About Output Device Programming.....	6-1
*79 Menu Mode: Output Device Mapping.....	6-1
*80 Menu Mode: Defining Output Functions.....	6-3
<b>Section 7. Zone Lists (*81 Menu Mode).....</b>	<b>7-1</b>
About Zone Lists .....	7-1
Zone List Programming .....	7-1
<b>Section 8. Function Key Programming (*57 Menu Mode) .....</b>	<b>8-1</b>
About Function Key Programming.....	8-1
Programming Function Keys.....	8-1
<b>Section 9. Alpha Descriptor Programming (*82 Menu Mode) .....</b>	<b>9-1</b>
About Descriptor Programming.....	9-1
Programming Zone Descriptors (program menu mode *82).....	9-1
Adding Custom Words (will not be annunciated by FA4285/FA4286 Phone Module).....	9-3
<b>Section 10. Creating Schedules.....</b>	<b>10-1</b>
About Schedules .....	10-1
<b>Section 11. System Communication.....</b>	<b>11-1</b>
<b>Section 12. System Operation.....</b>	<b>12-1</b>
Security Codes .....	12-1
Keypad Functions.....	12-2
Various System Trouble Displays .....	12-4
<b>Section 13. Testing the System.....</b>	<b>13-1</b>
About Test Procedures .....	13-1
System Test .....	13-1
Go/No Go Test Mode.....	13-2
Dialer Communication Test.....	13-3
<b>Section 14. Specifications &amp; Accessories.....</b>	<b>14-1</b>
Security Control .....	14-1
Compatible Devices .....	14-1
5800 Series Transmitter Input Loop Identification.....	14-3
<b>Section 15. Regulatory Agency Statements .....</b>	<b>15-1</b>
<b>Section 16. Limitations and Warranty .....</b>	<b>16-1</b>

# Features and Installation Highlights

This system is not certified as SIA compliant, but can be programmed for False Alarm Reduction. To program for False Alarm Reduction, follow the SIA Guidelines noted in the applicable programming fields..

The FA168C-GP control has the following major features:

## Capabilities

### Partitions

- Supports 2 partitions, which can protect two independent areas, as if each area had its own control.
- Common zone option allows either partition to arm, while leaving a common area (ex. lobby or foyer) disarmed for access into the other partition.

### Zones

- Supports up to 48 protection zones plus 16 keyfob zones (zones 49-64) for total of 64 zones:
  - 8 basic hardwired zones (zones 1-8) with optional zone-doubling feature
  - Up to 40 additional wired zones (zones 9-48) using up to 5 4219/4229 modules
  - Supports up to 40 wireless transmitter zones (5800 series; zones 9-48)
  - Supports up to 4 configurable zone types

### Security Codes

Up to 48 Security Codes, each with separate authority levels and partition access

Downloading: Via an IBM compatible computer, Compass downloading software, and a compatible HAYES or CIA modem specified by Ademco.

## Functions

- Single-button arming feature: Can use dedicated keys to arm the system AWAY or STAY
- Schedules (up to 32), to control devices and/or auto-arm/disarm the system
- Keypad macros (up to 4), which can be activated by wired keypads
- Paging feature allows certain system conditions to be reported to up to 4 pager phone numbers; can use a dedicated key on keypads to send a signal to a pager
- Built-in Telephone Line Monitoring option can monitor the telephone line voltage and can cause a local display, or a display and trouble/alarm sound.
- Event Logging records selected events (up to 100 events) in a history log; control and readout from the log is done via Ademco Compass Downloader software or installer/master code at Keypad
- Zone descriptors for all zones (useful only when using Alpha display keypads and/or the FA4285/FA4286 Phone Module).
- Optional bell supervision detects external sounder wiring short or open; causes a trouble condition, keypad display, and sends a report to the central monitoring station, if enabled.
- Optional RF jam detection for wireless systems detects a condition that may impede proper RF reception (i.e., jamming or other RF interference); causes keypad display, and sends a report to the central monitoring station (if trouble reporting is enabled).

## Compatible Devices

- Supports up to 8 Addressable Keypads: FA245KP Fixed-Word Display, FA260KP Fixed-Word Display Keypad, FA560KP Alpha Display Keypad, FA245RF, FA260RF Keypad/Transceivers
- Supports up to 2 AUI units, in addition to up to 8 keypads (described above)
- Supports 4219, 4229 addressable hardwire zone expander modules (up to 5 modules for up to 40 expansion zones)
- Supports 5881 series receiver and 5800 series transmitters
- Output relays and/or Powerline Carrier Devices (X-10 type) plus two on-board triggers (up to 16 relays/devices)
  - Use any combination of 4204, 4229 and or Powerline Carrier Devices.
  - Output functions (up to 48)
- FA4285/FA4286 Phone Module (Part. 1 only); provides access to the system via on premises or off-premises phones for arming, disarming, etc., plus control of relay outputs and Powerline Carrier devices.
- Audio Alarm Verification (using AAV module, such as ADEMCO UVS or Eagle Model 1250); can be used in conjunction with an output trigger to permit voice dialog between an operator at the central station and a person at the premises.
- Alarm output provides a 12VDC, 2 AMP output that can drive the compatible sounders; steady output for burglary/panic, or temporal pulse (3 pulses – pause – 3 pulses – pause – 3 pulses. . .) for fire. Uses current limiting circuitry for protection.
- Auxiliary Power Output: 12VDC, 600 mA maximum (uses fuse for protection).
- Backup Battery: Rechargeable (sealed lead-acid type) 12VDC, 4AH minimum.
- Long Range Radio: Primary telephone number messages can be reported via ECP connection to various Long Range Radios (check compatibility and availability of specific models)
- AC Power Supply: Plug-in 120VAC transformer, ADEMCO 1321 (1321CN in Canada) or, if using Powerline Carrier devices, ADEMCO 1361X10 Transformer Module

**NOTE:** All devices and accessories used in a Canadian installation must be Listed for use in Canada.

---

## Important Installation Highlights (Installer Please Read)

- This system uses addressable keypads and Zone Expander Modules (see table of addresses in **Programming Overview** section).
  - Keypads must be set for addresses 16-23 (first keypad is address 16, which is different from previous controls) and programmed in data fields \*190-\*196.
  - Zone Expander Modules must be set for specific addresses (07-11), based on the zone numbers used (see table of addresses in **4219/4229 Expansion Zones** section).
  - 4204 Relay Modules must be set for specific addresses (12-15; see **Connecting Relay Modules** section).
  - This control will not power-up unless AC power is connected (will not power-up on battery alone). However, once the system is powered up, it will operate on battery power in the event of AC loss.
  - Relays have two programming menu modes: Use \*79 Menu mode to map module addresses and device (output) numbers. Use \*80 Menu mode to define the output functions (see **Output Device Programming** section).
  - This system supports programmable function keys. Use \*57 Menu mode to define the function keys (see **Function Key Programming** section).
  - This system provides various paging features. Refer to the **Programming Overview** section for a summary on pager programming.
-

# Mounting and Wiring the Control

This section describes the procedures for mounting and wiring this control and its peripheral devices. In the following subsections, procedures are listed in the left column, while notes and pertinent explanations are provided in the right column.

## Cabinet and Lock

1. Mount the control cabinet to a sturdy wall in a clean, dry area, which is not readily accessible to the general public, using fasteners or anchors (not supplied) with the four cabinet mounting holes.
2. Remove cabinet door, then remove the lock knockout from the door. Insert the key into the lock.
3. Position the lock in the hole, making certain that the latch will make contact with the latch bracket when the door is closed. When correctly positioned, push the lock until it is held securely by its snap tabs.

## Notes

- The cabinet can be closed and secured without a lock by using 2 screws in the cover's edge.

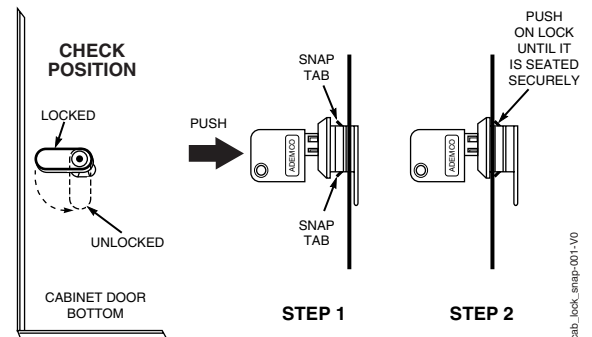

Figure 1. Installing the Cabinet Lock

## Mounting the PC Board Alone (no RF Receiver)

1. Hang two short mounting clips (provided) on the raised cabinet tabs (see Detail B in Fig. 2).
2. a. Insert the top of the circuit board into the slots at the top of the cabinet. Make sure that the board rests on the correct row (see Detail A).
- b. Swing the base of the board into the mounting clips and secure the board to the cabinet with the accompanying screws (see Detail B).

## Notes

- Before installing the cabinet's contents, remove the metal cabinet knockouts required for wiring entry. Do not remove the knockouts after the circuit board has been installed.

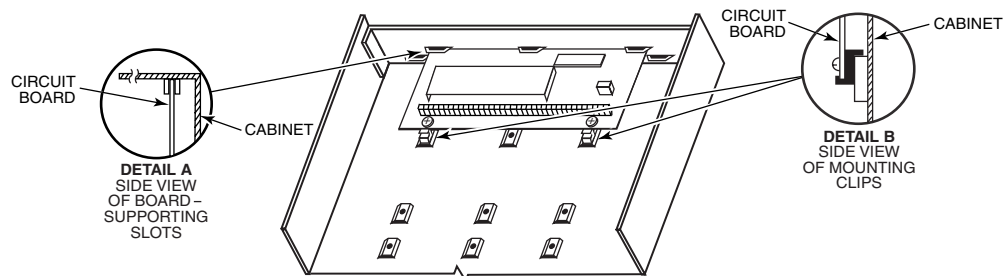

Figure 2. Mounting the PC Board

## Mounting Board with RF Receiver

1. a. Remove the receiver board from its case, then insert the top of the board into the slots at the top of the cabinet, as shown in Detail A in Figure 3. Make sure that the board rests on the correct row of tabs.
  - b. Swing the base of the board into the mounting clips and secure it to the cabinet with the accompanying screws.
  - c. Insert the top of the control's board into the slot in the clips and position two clips at the lower edge of the board.
  - d. Swing this board into place and secure it with two additional screws.
2. Insert grounding lugs (supplied with the receiver) through the top of the cabinet into the left-hand terminals of the antenna blocks (at the upper edge of the receiver board) and secure them to the cabinet top with the screws provided, as shown in Detail B.
3. Insert the receiver's antennas through the top of the cabinet, into the blocks' right-hand terminals, and tighten the screws.

## Notes

- Do not mount the cabinet on or near metal objects. This will decrease RF range and/or block RF transmissions from wireless transmitters.
- Do not locate the cabinet in an area of high RF interference (revealed by frequent or prolonged lighting of the LED in the receiver after it is operational (random flicker is OK))

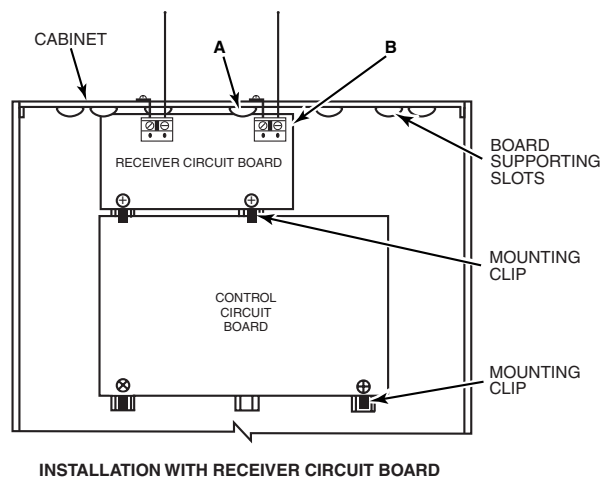

INSTALLATION WITH RECEIVER CIRCUIT BOARD

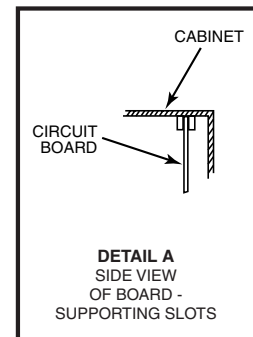

DETAIL A  
SIDE VIEW  
OF BOARD -  
SUPPORTING SLOTS

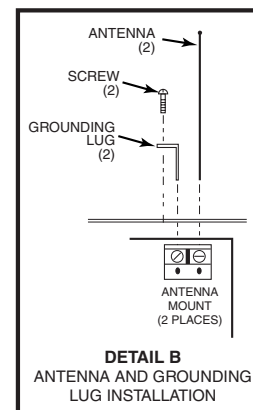
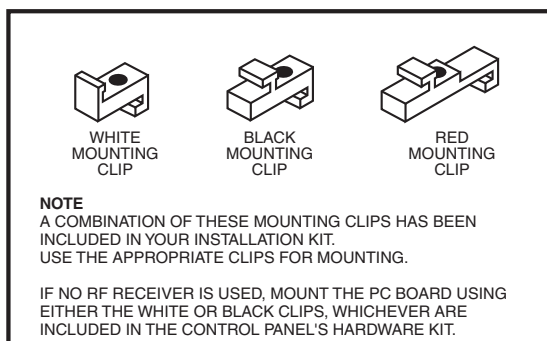

pc\_mount-001-V1

Figure 3. Mounting the PC Board and RF Receiver



## Wiring to Keypads

1. Connect keypads to the control's keypad terminals as shown on the Summary of Connections diagram. Determine wire size using the Wire Run Chart below.
2. Set keypad addresses. Refer to the address setting instructions included with the keypads and set each keypad device address according to the chart at right.
3. Program the keypad addresses, partition assignments and sound options in data fields \*190-\*196.

**NOTE:** Each keypad must be assigned a unique address, **starting at address 16**. Keypads programmed with the same address will give unpredictable results.

### Supplementary Power (optional)

1. Connect as shown. Be sure to connect the negative (-) terminal on the power supply unit to terminal 4 (AUX -) on the control.

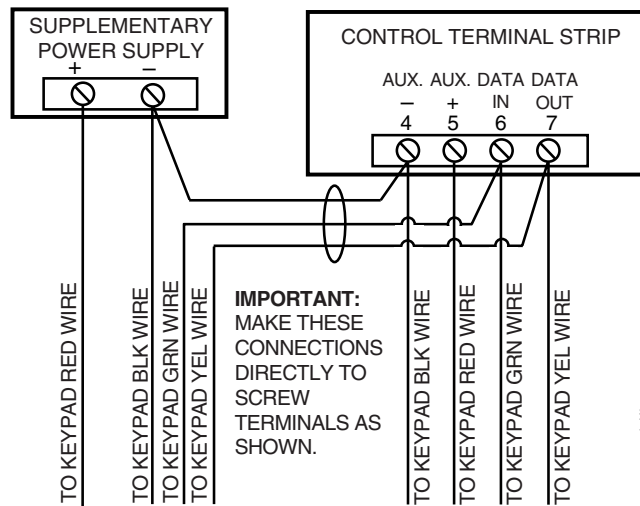

Figure 4. Using a Supplementary Power Supply

Keypads powered from supplies that do not have a backup battery will not function if AC power is lost. Make sure to power at least one keypad in each partition from the control's auxiliary power output.

## Notes

- Typical Fixed-Word Display: FA245KP, FA260KP
- Typical Alpha Display: FA560KP
- Keypad/Transceivers: FA245RF, FA260RF
- AUI: Up to two Symphony FA800KP (see note below) or FA700KP Touch Screen keypads
- The system supports up to 8 keypads, which can be assigned to partitions in any combination (see program fields \*190-\*196).
- For single 4-wire runs, determine the current drawn by all units, then refer to the Wiring Run chart to determine the maximum length that can be safely used for each wire size.
- Use supplementary power if the control's aux. power load for all devices exceeds 600mA. Suggested power supply: AD12612

### Keypad Addresses

Keypad	Address	Keypad	Address
no. 1	16**	no. 5	20
no. 2	17	no. 6	21
no. 3	18	no. 7	22
no. 4	19	no. 8	23

\*\* The **first keypad is address 16**, which is always enabled and set for partition 1 with all sounds on.

### AUI NOTE:

- Use of AUI is independent from standard keypads and does not affect the number of standard keypads the system can support.
- AUI keypads must be set for either address 1 or address 2, depending on which unit is enabled in field \*189.
- To ensure proper AUI device operation, connect only to controls having microprocessor version 3.0 or higher, and use AUI devices with the following rev levels: FA700KP series use version 1.0.9 or higher; FA800KP (Symphony) series use version 1.1.175 or higher.

**UL** Use a UL Listed, battery-backed supply for UL installations. The battery supplies power to these keypads in case of AC power loss. The battery-backed power supply should have enough power to supply the keypads with the UL required minimum standby power time.

Wire Run Chart For Devices* Drawing Aux Power From The Control (12V+ & 12V-)					
Wire Size	TOTAL CURRENT DRAWN BY ALL DEVICES CONNECTED TO A SINGLE WIRE RUN				
	50 mA or less	100 mA	300 mA	500 mA	600 mA
#22	900 ft (274m)	450 ft (137m)	150 ft (46m)	90 ft (27m)	75 ft (23m)
#20	1400 ft (427m)	700 ft (213m)	240 ft (73m)	140 ft (43m)	120 ft (37m)
#18	1500 ft (457m)	1100 ft (335m)	350 ft (107m)	220 ft (67m)	170 ft (52m)
#16	1500 ft (457m)	1500 ft (457m)	550 ft (168m)	350 ft (107m)	270 ft (82m)

\* Includes Keypads, RF Receivers, Zone Expander/Relay Units, or FA4285/FA4286 Phone Module.

Maximum wire lengths for any device that is homerun to the control can also be determined from the Wiring Run Chart, based on the current draw of that device alone.

The length of all wire runs for both partitions combined must not exceed 1500 feet (457m) when unshielded quad conductor cable is used (750 feet if shielded cable is used). This restriction is due to the capacitive effect on the data lines when quad cable is used.

### Sounder (Bell) Connections

1. Make sounder connections to alarm output terminals 3 (+) and 4 (-).  
For supervised output, continue with steps 2 and 3.
2. Cut the red Bell Supervision Jumper located above terminals 2 and 3 on the control board.
3. Connect a 2k ohm resistor across the terminals of the last sounder.

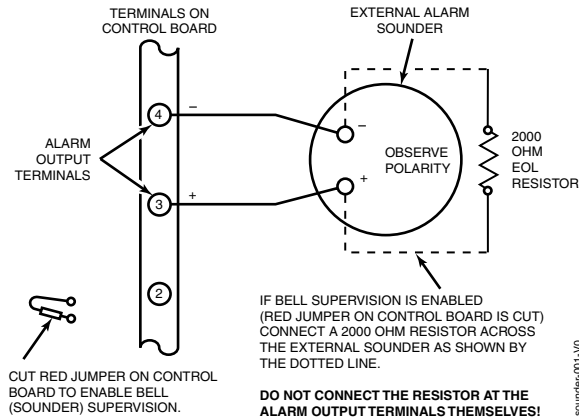

Figure 5. Sounder Wiring (Supervised)

### Notes

- This control complies with NFPA requirements for temporal pulse sounding of fire notification appliances. Temporal pulse sounding for a fire alarm consists of: 3 pulses – pause – 3 pulses – pause – 3 pulses–etc..
- The 12VDC sounder output activates when an alarm occurs.
  - Total current drawn from this output cannot exceed 2 amps (going beyond 2 amps will overload the power supply, or may cause the electronic circuit protecting the sounder output to trip).
  - You must install a battery, since the battery supplies this current.
- ### UL

  - Use only UL Listed sounding devices for UL installations.
  - Bell supervision is required for fire alarm installations.
  - The total current drawn from the alarm output and the auxiliary power output, combined, cannot exceed 600 mA. In addition, the sounding device must be a UL Listed audible signal appliance rated to operate in a 10.2-13.8 VDC voltage range, and must be mounted indoors.

### Wiring the AC Transformer

#### 1321 Transformer:

Connect the 1321 Transformer to terminals 1 and 2 on the control board. See Wire Run Chart at right for wire size to use. (Use 1321CN in Canada.)

#### 1361X10 Transformer

(required if using Powerline Carrier devices)

1. Splice one end of a 3-conductor cable to the wire ends of the SA4120XM-1 Cable.
2. Connect the SA4120XM-1 cable plug to the 8-pin connector on the control (see the Summary of Connections diagram for location of the 8-pin connector).
3. Connect the other end of the 3-conductor cable to the 1361X10 Transformer, as shown.

**Canada:** See Powerline Carrier Device section for connections to the PSC04 X-10 Interface and trigger pins.

### Notes

- Use caution when wiring the transformer to the control to guard against blowing the transformer fuse (the fuse is non-replaceable).
- Wiring to the AC transformer must not exceed 250 feet using 16 gauge wire. The voltage reading between terminals 1 and 2 of the control must not fall below 16.5VAC or an “AC LOSS” message will be displayed.
- Do not plug the transformer into the AC outlet while making any wiring connections to the control. As a safety precaution, always power down the control when making such connections.

### Wire Run Chart

Distance from control	Wire Size
Up to 50 feet	# 20
50–100 feet	# 18
100-250 feet	# 16

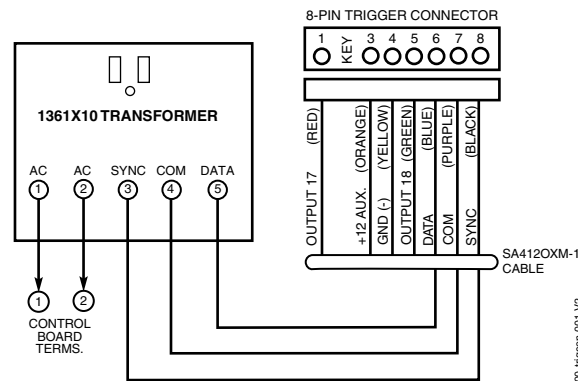

Figure 6. Connections of 1361X10 Transformer to the Control Board

## Backup Battery

1. Place the 12-volt backup battery in the cabinet.
2. After all connections to the control are completed and AC power has been applied, connect the red and black flying leads on the control board to the battery. Do not attach these leads to the battery terminals until all connections are completed.

**Battery Saver Feature:** The battery will disconnect from the system after its voltage decreases below 9VDC. This assists the control panel in recharging the battery when AC is restored.

## Notes

**IMPORTANT:** The panel will not power up initially on battery power only. You must plug the transformer in first, and then connect the battery.

**UL** For UL installations and Residential fire installations, refer to the chart below for the correct battery size required to meet the mandatory standby time.

### CALIFORNIA STATE FIRE MARSHALL (CSFM) AND UL RESIDENTIAL FIRE 24-HOUR BATTERY BACKUP REQUIREMENTS

The California State Fire Marshal and UL have regulations which require that all residential fire alarm control panels must be provided with a backup battery which has sufficient capacity to operate the panel and its attached peripheral devices for 24 hours in the intended standby condition, followed by at least 4 minutes in the intended fire alarm signaling condition. This control panel can meet these requirements without using a supplementary power supply, provided that the panel's auxiliary power and bell output currents are limited as indicated below.

OUTPUT LIMITATIONS TO MEET CSFM 24 HOUR BATTERY BACKUP REQUIREMENTS AND UL RESIDENTIAL FIRE INSTALLATIONS			
OUTPUT CURRENT LIMITATIONS		BATTERY INFORMATION	
Output Current Total	Maximum Auxiliary Current	Battery Capacity To Use (Amp/Hrs)	Recommended Battery (Yuasa Model No.)
600mA maximum total of auxiliary power plus bell output currents	45mA	4AH	NP4-12 (or ADEMCO 467)
	160mA	7AH	NP7-12
	200mA	8AH	NP4-12 (two) ‡
	425mA	14AH	NP7-12 (two) ‡
	500mA	17.2AH	NP618-12

‡ **NOTE:** Use two batteries, connected in parallel. Obtain an Ademco Battery Harness Kit SA5140-1. (Both batteries will fit inside the panel's cabinet.)

## Earth Ground

### Metal Cold Water Pipe:

Use a non-corrosive metal strap (copper is recommended) firmly secured to the pipe to which the ground lead is electrically connected and secured.

### AC Power Outlet Ground:

Available from 3-prong, 120VAC power outlets only. To test the integrity of the ground terminal, use a 3-wire circuit tester with neon lamp indicators, such as the UL Listed Ideal Model 61-035, or equivalent, available at most electrical supply stores.

## Notes

- This product has been designed and laboratory-tested to ensure its resistance to damage from generally expected levels of lightning and electrical discharge, and does not normally require an earth ground.
- If an earth ground is desired for additional protection in areas of severe electrical activity, terminal 25 on the control board, or the cabinet, may be used as the ground connection point. The examples of good earth grounds listed at the left are available at most installations.

### AUXILIARY DEVICE CURRENT DRAW WORKSHEET

DEVICE	CURRENT	# UNITS	TOTAL CURRENT
FA245KP Keypad	30 mA		
FA260KP Keypad	75 mA		
FA560KP Keypad	80 mA		
FA245RF Keypad/Transceiver	105 mA		
5881/5882 RF Receiver	35mA		
5883 Transceiver	80mA		
4219 Zone Expander	35mA		
4204 Relay Unit	15/180mA†		
4229 Zone Expander/Relay Unit	35/100mA†		
FA4285 Phone Module	160mA		
FA4286 Phone Module	300mA		
*			
(Current available from Aux. terminals = 600 mA max.)† <b>TOTAL =</b>			

\* If using hardware devices such as PIRs, refer to the specifications for that particular unit's current draw.

† In UL installations, maximum current draw from the Auxiliary Output and the Alarm Output **combined** must not exceed 600 mA (500 mA max from Auxiliary Output).

‡ Figures are for relays OFF/relays ON.

## Hardwire Zones

### Normally Open Zones/ Normally Open EOLR Zones

1. Connect open circuit devices in parallel across the loop; for EOLR zones, connect the EOLR across the loop wires at the last device.
2. Enable normally open/EOLR zones using Zone Programming mode, “Hardwire Type” prompt.

### Normally Closed Zones/Normally Closed EOLR Zones

1. Connect closed circuit devices in series in the high (+) side of the loop; for EOLR zones, connect the EOLR in series following the last device.
2. Enable normally closed/EOLR zones using Zone Programming mode, “Hardwire Type” prompt.

**Double-Balanced:** Connections as shown below (resistor provided for one device).

**IMPORTANT:** Double-balanced zones provide zone tamper protection, and should be used as burglary zones only. Do not use double-balanced zones as fire zones.

**Zone Doubling:** Connections as shown below (resistors provided).

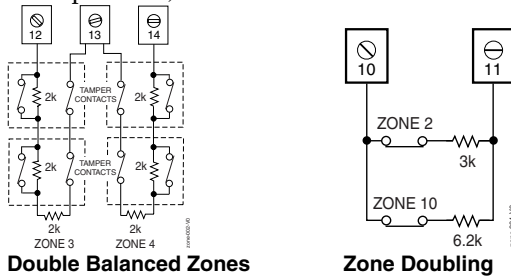

Double Balanced Zones

Zone Doubling

## Notes

- **EOLR:** If the EOLR is not at the end of the loop, the zone is not properly supervised, and the system may not respond to an “open” on the zone.
- Zone 1 is intended for EOLR only.

**UL** For UL commercial burglar alarm installations, use EOLR zones.

### Zone Doubling:

This feature provides two hardwired normally closed zones for each standard hardwired zone connected to the control’s terminals (but does not increase the total number of zones supported by the control). If enabled (Zone Programming mode, “Hardwire Type” prompt, option “3”), hardwire zones are automatically paired as follows:

Zone	Paired with zone
2	10
3	11
4	12
5	13
6	14
7	15
8	16

**Do not use zone doubling for fire zones.**

**NOTE:** A short across the EOL (i.e., at terminal) on either zone of a zone-doubled pair or on a double-balanced zone causes a tamper condition (displayed as CHECK plus zone numbers).

## Smoke Detectors

### 2-Wire Smoke Detectors

1. Connect up to sixteen (10, if “clean me” option used) 2-wire smoke detectors across zone 1 terminals 8 (+) and 9 (-) as shown in the Summary of Connections diagram at the back this manual. Observe proper polarity when connecting the detectors.
2. Connect an EOL resistor across the loop wires at the last detector.

## Notes

- **Fire Verification (zone type 16):** The control panel will “verify” a fire alarm by resetting the smoke detectors after the first alarm trigger, and then waiting 90 seconds for a second alarm trigger. If the smoke detector or thermostat does not trigger again, the control will disregard the first trigger, and no alarm signal will occur. This feature eliminates false alarms due to electrical or physical transients.
- **SIA Installations:** If using fire verification on zones other than zone 1, UL Fire Alarm Listed relay accessories must be used to reset power as described in step 3 at left.
- The zone 1 alarm current supports only one smoke detector in the alarmed state.
- **Clean Me Option:** If enabled (field \*174 = 1; \*56 zone programming, response time prompt = 3), certain ESL smoke detectors† send “clean me” reports as appropriate. If used, the maximum number of detectors is reduced to 10 (not standard 16).

† Refer to the ESL documentation included with the smoke detector for information regarding compatibility with the clean-me option.

## Smoke Detectors (continued)

### 4-Wire Smoke Detectors

3. Connect 4-wire smoke detectors (up to 16, depending on detector current draw) to any zone from 2-8 as shown below.

This control does not automatically reset power to 4-wire smoke detector zones, so you must use a relay (e.g., 4204, 4229), or on-board trigger to reset power (also required for fire verification). Do this by programming the designated relay/trigger as zone type 54 (fire zone reset); see On-Board Trigger section for other information.

**NOTE:** Maximum current on trigger 17 is 100mA.

### Notes

- Do not use 4-wire smoke detectors on zone 1.

**Figure 7. 4-Wire Smoke Detector Connections**

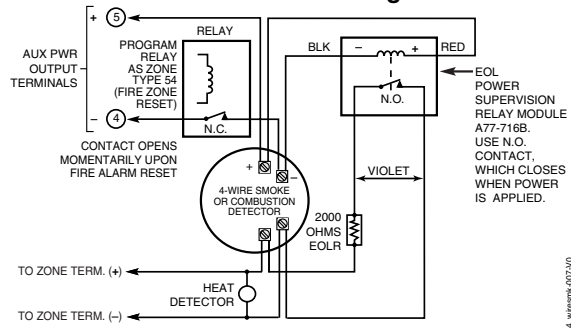

**4-Wire Smoke Detector Using Relay for Power Reset**

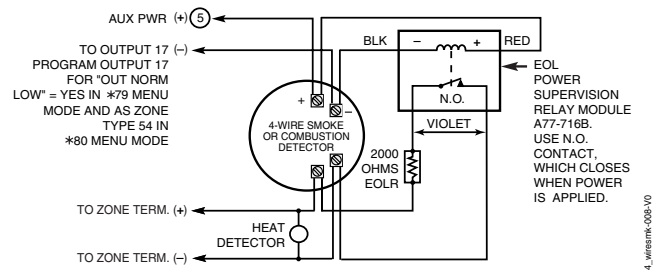

**4-Wire Smoke Detector Using Output 17 for Power Reset**

### 4219/4229 Expansion Zones

1. Connect each module to the control's keypad terminals.
2. Assign each module a unique device address using its DIP switches. Device address determines the zone numbers, as shown in the table below.

#### Expander Module Addresses

For Zones...	Set Module to Device Address...
09-16	07 (not available if zone-doubling enabled)
17-24	08
25-32	09
33-40	10
41-48	11

3. Connect sensors to the module's loops.
4. If using relays with the 4229, connect the desired field wiring to the unit's relay contact terminals.

### Notes

- Supports up to 40 expansion zones (NO or NC) using up to five 4219/4229 Zone Expander Modules.
- Use 1000 ohm end-of-line resistors at the end of loops connected to the 4219/4229 modules. (End-of line resistors used on the control terminals are 2000 ohms.)
- Expansion zones have normal response time (300–500 msec), except zone connected to each module's loop "A," which can be set for fast response (10–15 msec).

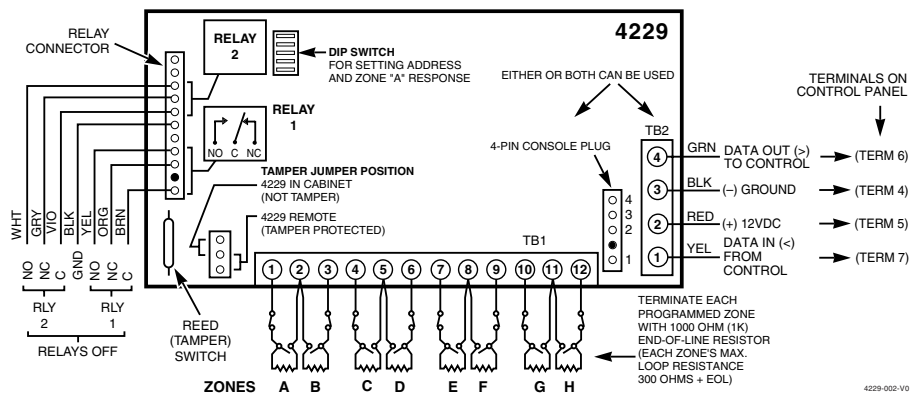

Figure 8. Wiring Connections, 4219 & 4229 (4229 shown)

## Installing the RF Receiver

Use any 5800 Series Wireless Receivers, such as:

RF Receiver	No. of Zones
5881L/5882L	up to 8
5881M/5882M	up to 16
5881H/5882H	up to 40
5883	

1. Set Device Address to "00" as described in its instructions (set all switches to the right, "off" position).
2. Mount the receiver, noting that the RF receiver can detect signals from transmitters within a nominal range of 200 feet.
3. Connect the receiver's wire harness to the control's keypad terminals. Plug the connector at the other end of the harness into the receiver. Refer to the installation instructions provided with the receiver for further installation procedures regarding antenna mounting, etc.

## Notes

- The receiver is supervised and a trouble report is sent ("CHECK 100" displayed) if communication between the panel and receiver is interrupted, or if no valid RF signals from at least one supervised transmitter are received within 12 hours.

If the receiver is mounted remotely:

- Place the RF receiver in a high, centrally located area for best reception.
- Do not locate the receiver or transmitters on or near metal objects. This will decrease range and/or block transmissions.
- Do not locate the RF receiver in an area of high RF interference (indicated by frequent or prolonged lighting of the LED in the receiver; random flicker is OK).
- Do not locate RF receiver closer than 10 feet from any keypads to avoid interference from the microprocessors in those units.

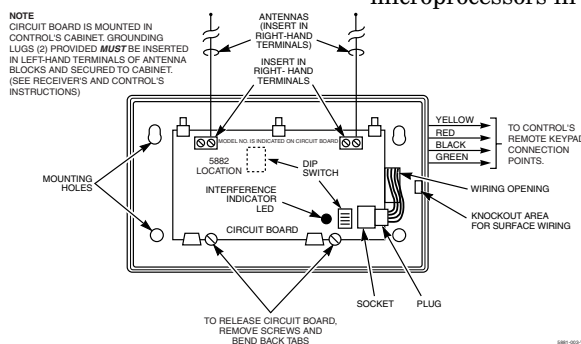

Figure 9. 5881/5882 RF Receiver (cover removed)

## Installing a 5800TM Module

1. Mount the 5800TM next to the RF receiver (between one and two feet from the receiver's antennas) using its accompanying mounting bracket. Do not install within the control cabinet.
2. Connect the 5800TM to the control panel's keypad connection terminals as shown on the Summary of Connections diagram and set to address 28.

## Notes

- Use this module only if you are using one or more wireless bi-directional keypads or keyfobs with a wireless Receiver; 5800TM is not necessary if using a Transceiver (e.g., 5883).
- The 5800TM must be set to address 28 (cut red-W1 jumper).
- The 5800TM can be used in partition 1 only.
- For additional information regarding the 5800TM, refer to the 5800TM's instructions.

## Installing the Transmitters

1. To be sure reception of the transmitter's signal at the proposed mounting location is adequate, perform a Go/No Go Test, described in the *Testing the System* section.
2. Install transmitters in accordance with the instructions provided with each.
3. Set 5827, 5827BD, 5804BD transmitters to the programmed House ID (field \*24), using its DIP switches (5827) or follow the instructions provided with the device.

## Notes

- Refer to the table of compatible devices at the back of this manual.
  - Supervised transmitters<sup>†</sup> send check-in signals to the receiver at 70-90 minute intervals. If at least one check-in message is not received from each transmitter within a 12-hour period, the "missing" transmitter number(s) and "CHECK" is displayed.
- <sup>†</sup> Hand-held transmitters (e.g., 5802, 5802CP, 5804, 5804BD, 5827, 5827BD) do not send check-in signals.

**UL** The following transmitters are not intended for use in UL installations: 5802MN, 5802MN2, 5804, 5804BD, 5814, 5816TEMP, 5819, 5819WHS & BRS, and 5850. The 5827BD and 5800TM can be used in UL Listed Residential Burglar installations.

**Transmitter Battery Life**

- See Wireless Transmitter paragraph in the *Limitations of This Alarm System* statement located at the end of this manual for information on transmitter battery life.
- Some transmitters (e.g., 5802 and 5802CP) contain long-life but non-replaceable batteries, and no battery installation is required. At the end of their life, the complete unit must be replaced (and a new serial number enrolled by the control).
- Button-type transmitters (such as 5801, 5802, and 5802CP) should be periodically tested for battery life.
- The 5802MN and 5804 Button Transmitters have replaceable batteries.

Do not install batteries in wireless transmitters until you are ready to enroll during system programming. After enrolling, batteries need not be removed.

**Installing a Keyswitch**

1. Connect the 4146 keyswitch's normally open momentary switch to a zone's (2-8) terminals. Remove the 2000 ohm EOL resistor if connected across the selected zone.
2. Using a standard keypad cable as shown: Connect the yellow and white keyswitch wires to trigger connector pin 3 (+12V). Connect the Red and Green LED wires to the appropriate output 17/output 18 trigger connector pins.
3. Connect a 2000 ohm EOL resistor across the momentary switch.
4. You can wire an optional closed-circuit tamper switch (model 112) in series with the zone. If the switchplate is then removed from the wall, the tamper will open, disabling keyswitch operation until the system is next disarmed from the keypad. If the tamper is opened when the system is armed, an alarm will occur.

**UL** A UL Listed keyswitch is required for fire installations and UL commercial and residential burglar alarm installations.

If a keyswitch is used on:

- an installation that transmits opening and closing signals, the keyswitch zone must be programmed to send opening and closing signals.
- a UL commercial burglar alarm installation, the keyswitch's tamper switch must be connected in to the alarm system. This tamper switch zone must also be programmed for Zone Type 05 – Trouble by Day / Alarm by Night.
- a fire alarm installation, the keyswitch must be located next to an alphanumeric display keypad.

The Ademco 4146 keyswitch is UL Listed.

**Notes**

- Use 4146 keyswitch or any N.O. keyswitch.
- Use only one keyswitch per partition.
- When using a keyswitch, the zone it is connected to is no longer available for use as a protective zone.
- Use \*56 Menu mode to program the keyswitch zone and assign it zone type 77.
- Use \*80 Menu mode to program the LED functions: program outputs 17 and 18 for system operation zone type 78 (red LED) and 79 (green LED) as appropriate (see **Output Device Programming** section).

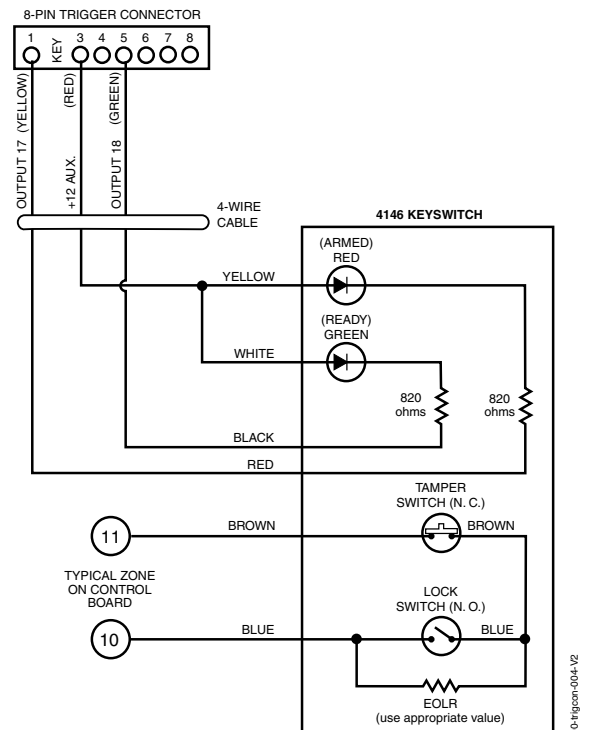

Figure 10. Keyswitch Wiring Connections



### Connecting Relay Modules

1. Mount either remotely or in the control panel.
2. Connect to control's keypad terminals using the connector harness supplied with the module. Use standard 4-conductor twisted cable for long wiring runs.
3. Set each module's device address according to the table at right.
4. Connect the desired field wiring to the unit's relay contact terminals.

**UL** For UL installation requirements, refer to the Installation Instructions for the 4204.

### Notes

- Use 4204 or 4229 modules.
- Supervision: 4204 and 4229 modules are supervised against removal. The module's device address is displayed as follows if a module is disconnected from the control's terminals, or if the module cover is removed and the tamper jumper is installed:  
 Alpha: CHECK xx Wire Expansion  
 FAULT xx Wire Expansion  
 ALARM xx Wire Expansion  
 Fixed-Glass: lxx (or 91 if field \*199 set for 2-digit display)  
 where "xx is the module's address.
- If communication/tamper failure occurs on a device with zones wired to it, all zones on the device will be displayed in their respective partitions.

### Relay Module Addresses

4204	Address	4229	Address
no. 1	12	no. 1 (zn 09-16)	07
no. 2	13	no. 2 (zn 17-24)	08
no. 3	14	no. 3 (zn 25-32)	09
no. 4	15	no. 4 (zn 33-40)	10
		no. 5 (zn 41-48)	11

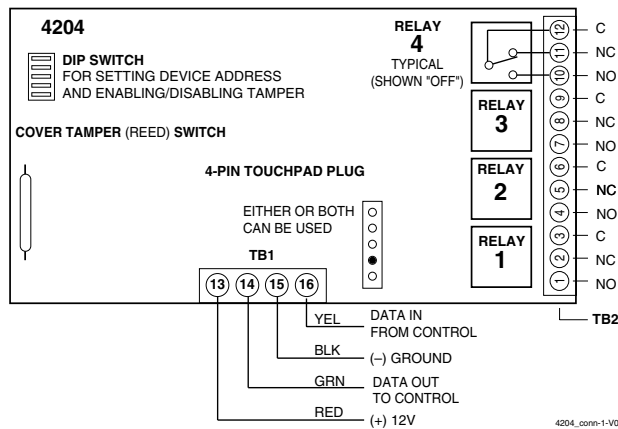

**Figure 11. 4204 Connections to Control**  
 (4229 Module is shown in the 4219/4229 Expansion Zones paragraph on page 2-7)

## Powerline Carrier Devices

1. Install the powerline carrier devices (up to 16 devices (if no relays are used) according to the instructions included with each.
2. Use Programming Mode to enter the device house ID in data field\*27, and enter the unit code using \*79 Output Device menu Mode.
3. See connections diagram in the AC Wiring paragraph for connecting the 1361X10 transformer to the triggers.

Canada: Use the PSC04 Powerline Interface as shown below.:

## Notes

- When using Powerline Carrier devices, you must use a 1361X10 Transformer instead of the 1321 Transformer.
- The 1361X10 Transformer provides AC power to the control panel, and also supplies signals from the control panel through the premises AC wiring to the Powerline Carrier devices (which are plugged into AC outlets). You can then make devices that are plugged into Powerline Carrier devices perform various functions in response to commands you enter at the security system keypads.

**UL** Powerline Carrier devices are not UL Listed for fire or burglary functions and are intended for home automation.

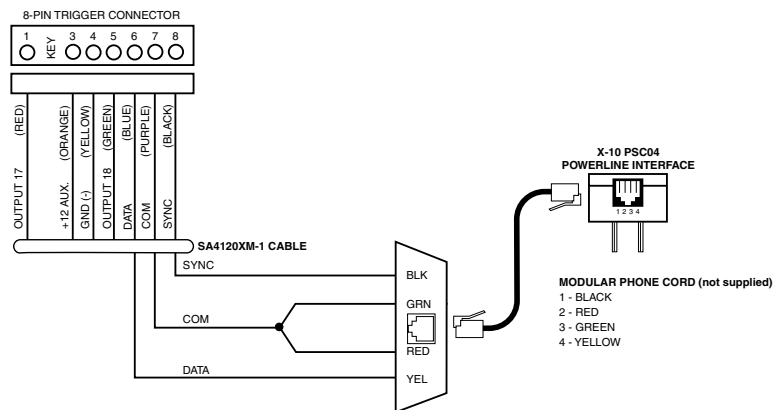

**PSC04 Powerline Interface Connections**

## On-Board Triggers

Connect field wiring to the desired trigger pin on the 8-pin trigger connector centrally located above the terminal strip.

- If using 1361X10 transformer and powerline carrier devices, use the SA4120XM-1 cable (part of 4120TR Trigger Cable). See *Wiring the AC Transformer* section for transformer connections.
- If only using the on-board triggers, you can use a 4-wire cable (N4632-4, supplied with the control) as shown below.

**UL** If on-board triggers are used, the wiring between the control unit and the UL Listed device must be run in conduit, be no more than 3 feet apart and have no intervening barriers or walls.

## Notes

- There are two on-board triggers that can be used to activate output devices.
- These outputs are normally high, and go low upon programmed condition.
- The outputs can be programmed for inverted operation (normally low, go high) using \*79 Menu mode.
- Program these triggers using \*80/\*81 Menu modes as you would for any other relay output.
- When using these outputs, note:
  - pin 1 = output number 17 (trigger 1):  
15 ohms to ground when closed (output low), open when off (output high, normal default); can be used to reset smoke detector power (must set “output normal low = yes” in \*79 Menu mode, and set for zone type 54, fire zone reset, in \*80 Menu mode); or can support 12V relay module<sup>†</sup> that draws less than 100mA
  - pin 5 = output number 18 (trigger 2):  
100 ohms to ground when closed (output low); open when off (output high, normal default); or can support 12V relay module<sup>†</sup> that draws less than 20mA

<sup>†</sup> e.g., Altronix AX-RBS

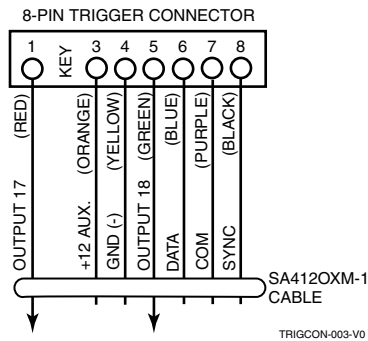

Figure 12. On-Board Trigger Connector with SA4120XM-1 Cable for Use With 1321X10 Transformer

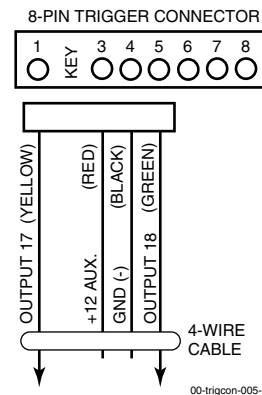

Figure 13. On-Board Trigger Connector with 4-Wire Cable for Trigger Use Only

## Phone Line/Phone Module Connections

1. Connect incoming phone line and handset wiring to the main terminal block (via an RJ31X jack) as shown in the Summary of Connections diagram at the back of this manual. Wire colors represent the colors of the cable to the RJ31X jack.

If using a phone module, continue with the following steps.

2. Make 12V (+) and (-) and data in and data out connections from the phone module to the control, using the connector cable supplied with the phone module, then insert the keyed connector at the other end of the connector cable into the header on the phone module.
3. Connect Phone Module terminals as shown below. Use an RJ31X jack with a direct-connect cord and make all connections exactly as shown.
4. Caller ID Units: If a Caller ID unit is being used, connect the unit directly to the "Handset" terminals (21 & 22) on the control, as shown.

## Notes

- Use FA4285 or FA4286 Phone Modules. Compatibility: FA4286 Phone Modules must have software version WA4286-15.1 or higher (refer to the label on the square FA4286 microprocessor chip).
- Only one phone module can be used and it can only be connected to partition 1.
- The phone lines must be in service for the phone module to function, even when accessing the system from an on-premises phone.
- If you are also using an Audio Alarm Verification (AAV) unit, refer to *Audio Alarm Verification (AAV)* section for special wiring connections.

**CAUTION:** To reduce the risk of fire, use only No. 26 AWG or larger telecommunication line cord for phone line connections.

**UL** The FA4285 and FA4286 modules are UL Listed only for use on residential fire and UL residential burglar alarm installations.

## Phone Module Problems

If no touch tones are produced following access to the security system from on-premises (this problem may arise in rare cases), it may be necessary to reverse the wires connected to terminals 3 and 4 on the phone module and the wires connected to terminals (21) & (22) on the control. The wiring diagram shows the wiring connections that will provide proper operation in most cases.

Connection to the incoming telco line via a RJ31X jack and direct-connect cord, as shown, is essential, even if the system is not connected to a central station. The FA4285 or FA4286 will not function if this is not done and an error signal (fast busy signal) will occur when trying to access the system via the phone.

The house phone lines (gray and brown wires) must be wired to the phone module terminals; not to the control terminals. Otherwise, an error signal (fast busy signal) will occur when trying to access the system from an on-premises phone.

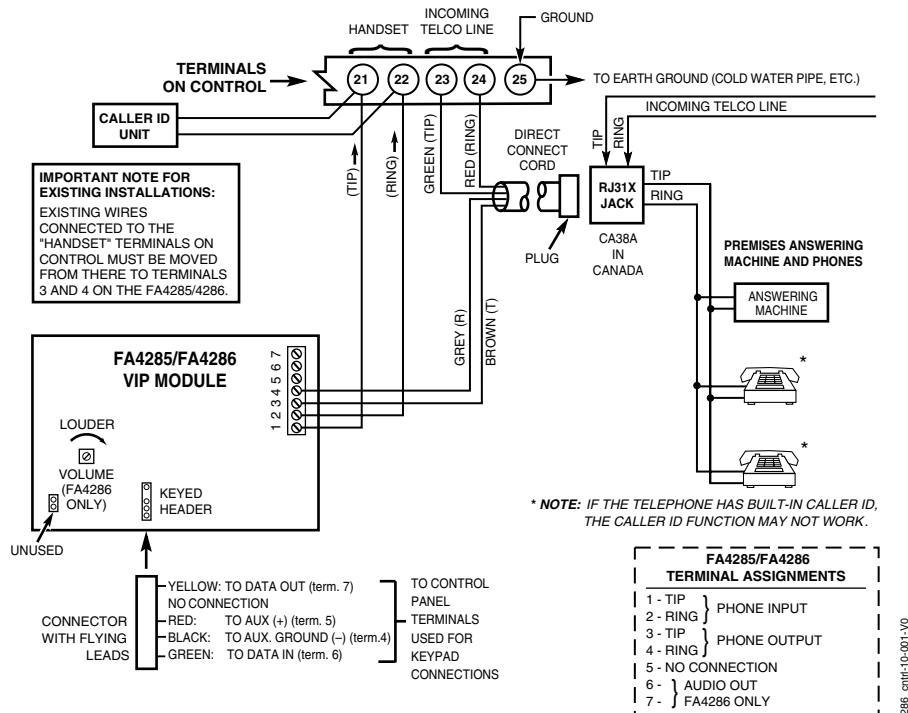

Figure 14. FA4285/FA4286 Phone Module Wiring Connections

### Long Range Radio Connections

Connect the data in/data out terminals and voltage input terminals of the Long Range Radio to the control's keypad connection points.

Set the radio's address to "03" following the instructions provided with the radio.

### Notes

- Use compatible Long Range Radios (e.g., 7720PLUS, 7820, 7835C, or 7845C).

### Audio Alarm Verification Connections (AAV, "listen-in")

Refer to the connection diagrams below. One diagram shows connections when a FA4285/FA4286 Phone Module is used, the other shows connections when the FA4285/FA4286 is not used.

Connections use one of the on-board triggers.

### Notes

- Set field \*91 for AAV and program the appropriate output (output 17 or 18) using \*80 Menu mode (select zone type "60").
- For voice session monitoring, connect a zone to UVCN module terminals 6 & 7, and program the zone as zone type 81 (\*56 Menu mode). E.g., Using output 18 for the trigger, program an output function in \*80 Menu as: ZT = 60, P = 0, Action = 1, Device = 18

**UL** UL installations using the AAV feature must use the ADEMCO UVCN module (part of the ADEMCO UVS system).

Suggested AAV Module: ADEMCO UVS (shown) or Eagle 1250

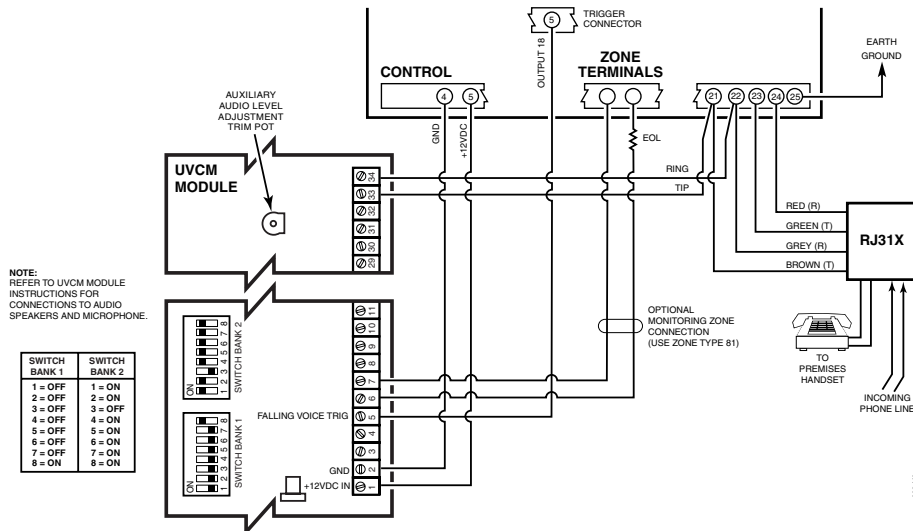

Figure 15. Connection of AAV Unit When Not Using a FA4285/FA4286 Phone Module

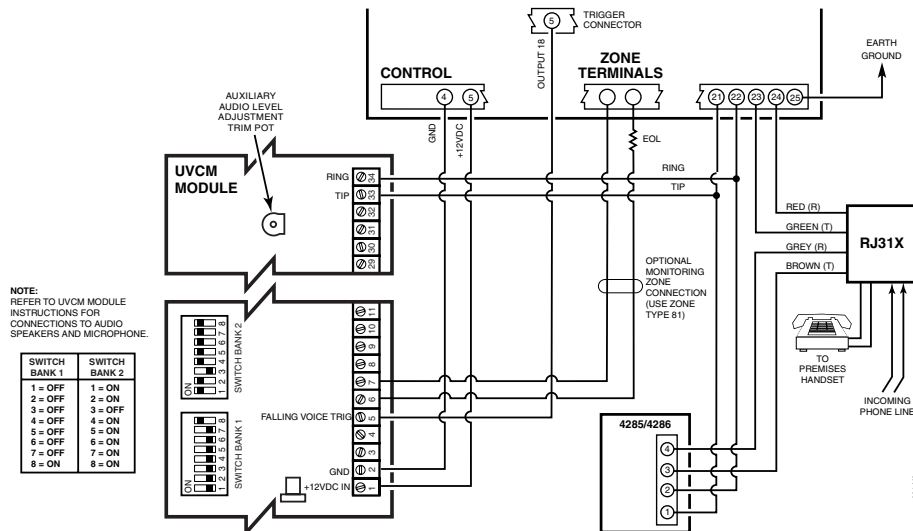

Figure 16. Connection of AAV Unit When Using a FA4285 or FA4286 Phone Module



# Programming Overview

## About Programming

You can program the system at any time, even at the installer's premises prior to the actual installation. Programming can also be performed remotely from the installer's office/home, using an IBM personal computer, a modem, and Compass downloading software.

The following is a list of the various Programming modes used to program this system:

Programming Mode...	Used to ...
Data Field Programming	Program basic data fields used for setting the various system options. Most of the data fields in this system have been programmed for specific default values. However, some fields must be programmed for each particular installation to establish its specific alarm and reporting features.
*56 Zone Programming	Assign zone characteristics, report codes, alpha descriptors, and serial numbers for 5800 RF transmitters.
*57 Function Key Programming	Program each of the four alphabet function keys to perform one of several system operations.
*58 Zone Programming (Expert Mode)	Assign zone attributes similar to *56 mode, but provides a faster programming procedure and is intended for those more experienced in programming controls of this type.
*79 Output Device Mapping	Assign device addresses used by 4229 or 4204 Relay modules and map specific relays and device outputs, and assign unit codes for Powerline Carrier devices
*80 Output Definitions	Define up to 48 output definitions which can control the output relays mapped using *79 Output Device Mapping mode.
*81 Zone List Programming	Create Zone Lists for relay/powerline carrier zones, chime, night-stay, cross zones, and pager zones.
*82 Alpha Programming	Create alpha descriptors for easy zone identification.
Scheduling Mode (code + [#] +64)	Create schedules to automate various system functions.

## Zones and Partitions

Each protection zone needs to be programmed with various attributes using \*56 Zone Programming mode or \*58 Expert Programming mode. Refer to those sections for detailed procedures.

The system can control two independent areas of protection (known as partitions) for use by independent users, if desired, by simply assigning zones to one or the other partition during zone programming. The system, by default, automatically distributes users between the two partitions.

The master user can change the user number distributions.

Zones can also be assigned to a common partition, which is an area shared by users of both partitions (such as a lobby in a building). This allows either partition to arm, while leaving the common partition disarmed for access into the other partition. The following describes the functioning of the common partition:

- The common zone sounds and reports alarms only when both partitions are armed. If only one partition is armed, the system ignores faults on the common zone.
- Either partition may arm its system if the common zone is faulted, but once armed, the other partition will not be able to arm unless the common zone is first bypassed or the fault is corrected.
- Faults on the common zone are displayed on common zone keypads, and will also appear on another partition's keypad when that partition is armed.
- Either partition can clear and restore the common zone after an alarm.

## Keypads

Keypads are identified by predefined addresses (starting at address 16) as follows:

Address	Keypad	Program Field
16	keypad 1	• always enabled for partition 1, all sounds enabled.
17	keypad 2	• data field *190
18	keypad 3	• data field *191
19	keypad 4	• data field *192
20	keypad 5	• data field *193
21	keypad 6	• data field *194
22	keypad 7	• data field *195
23	keypad 8	• data field *196

**NOTE: First keypad address is 16.**

### To enable keypads:

1. Set desired address at keypad (refer to keypad's instructions for setting the address).
2. Use data field program mode to enable keypad addresses, assign a partition, enable sound options in fields \*190-\*196 as shown in the table above.
3. If desired, use data field \*198 to turn on the display of the partition number.
4. Set the following keypad-related data fields as required by the installation:  
\*21 Quick Arm Enable; \*23 Forced Bypass; \*84 Auto STAY Arm
5. If using AUI, enable each unit in field \*189 and set AUI 1 to address 1, AUI 2 to address 2.

## Wireless Receiver, Transmitters, and Wireless Keys (keyfobs)

**Receiver:** Set the receiver's address to "00" using its DIP switches, then set the following options:

- \*22 RF Jam Option<sup>†</sup>
- \*24 RF House ID Code (if using wireless keypads) for each partition
- \*67 Transmitter Low Battery Report Code<sup>†</sup>
- \*75 Transmitter Low battery restore report code<sup>†</sup>

<sup>†</sup> These fields must be enabled for Residential Fire, UL Residential Burglar Alarm, and UL Commercial Burglar Alarm installations.

**Transmitters:** Use \*56 or \*58 Zone Programming Menu modes to program zone information and enroll transmitters.

**Wireless Keys:** Use Wireless Key Programming Templates section of the \*58 Zone Programming Menu mode to program zone information and enroll each button of the wireless keys used. Once a wireless key is enrolled, it must be assigned to a user before it becomes active. See Adding/Deleting Security Codes section for procedure.

## Pager Programming

The system can send various reports to up to 4 pagers. To program pager reporting, do the following:

1. Enter the appropriate information in the following data fields:  
\*160, \*163, \*166, \*169 Pager Phone Numbers (for pagers 1-4 respectively)  
\*161, \*164, \*167, \*170 Pager Prefix Characters (for pagers 1-4 respectively)  
\*162, \*165, \*168, \*171 Pager Reporting Options by Partition (for pagers 1-4 respectively)
2. Enable Pager Delay, if desired, in field \*172 (delays alarm reporting for ALL pagers).
3. Make sure appropriate user open/close pager reports are enabled (see Security Codes, Assigning Attributes in **Section 12 System Operation**).  
Users that perform actions in partition 1 will, if enabled, attempt to report to all pagers enabled for open/close reporting in partition 1. Users that perform actions in partition 2 will, if enabled, attempt to report to all pagers enabled for open/close reporting in partition 2.
4. If using latchkey pager report, define the latchkey report schedule using Scheduling mode (master code + [#] [6] [4], select event type "03"). System must be armed for the Latchkey report to be sent.
5. If using a function key to manually send a message to a pager, see Function Keys paragraph on the next page.
6. If reporting zone alarms and troubles to a pager, use \*81 Zone List menu mode to assign the zones associated with each pager (zone lists 9-12).



## Function Keys

To assign functions to the function keys, use \*57 Function Key menu mode.

To assign emergency key functions (function key option “00”), first program the respective emergency zone number (95 for “A” key, 96 for “C” key, 99 for “B” key) with the desired zone type using \*56 Zone Programming mode, then use \*57 Function Key menu mode to assign the desired key.

If using a function key to activate a relay action (\*57 Menu mode key function 07), use \*79 Menu mode to map the output, and use \*80 Menu mode to define the output’s action; select system operation type “66.”

If using a function key for a user macro, use \*57 menu mode to activate the desired key, then define the actual macro functions using the user code + [#] + [6] [6] command.

## Output Devices

To program a device for manual activation (user code + [#] [7] / [#] [8] + 2-digit device number) or for scheduled automatic activation, simply map the device using \*79 Menu mode.

To program a device to automatically activate upon a system event (or function key), use \*79 Menu mode to map the device, then use \*80 Menu mode to define the automated device action.

If the device action is based on more than one zone, use \*81 Zone List menu mode to assign the zones.

---

## Zone Type Definitions

You must assign a zone type to each zone, which defines the way in which the system responds to faults in that zone. Zone types are defined below.

Zone Type	Description
<b>Type 00: Zone Not Used</b>	Program a zone with this zone type if the zone is not used.
<b>Type 01 Entry/Exit Burglary #1</b>	<ul style="list-style-type: none"><li>• Assign to zones that are used for primary entry and exit.</li><li>• Provides entry delay when zone is faulted if control is armed in the Away, Stay, or Night-Stay modes.</li><li>• No entry delay provided when the panel is armed in the Instant/Maximum mode.</li><li>• Entry delay #1 is programmable for each partition (field *35).</li><li>• Exit delay begins whenever the control is armed, regardless of the arming mode selected, and is independently programmable (field *34).</li></ul>
<b>Type 02 Entry/Exit Burglary #2</b>	<ul style="list-style-type: none"><li>• Assign to zones that are used for entry and exit and require more time than the primary entry/exit point.</li><li>• Provides a secondary entry delay, in same manner as entry delay #1.</li><li>• Entry delay #2 is programmable for each partition (field *36).</li><li>• Exit delay is same as described for Type 01.</li></ul>
<b>Type 03 Perimeter Burglary</b>	<ul style="list-style-type: none"><li>• Assign to all sensors or contacts on exterior doors and windows.</li><li>• Provides an instant alarm if the zone is faulted when the panel is armed in the Away, Stay, Night-Stay, Instant or Maximum modes.</li></ul>
<b>Type 04 Interior Follower</b>	<ul style="list-style-type: none"><li>• Assign to a zone covering an area such as a foyer, lobby, or hallway through which one must pass upon entry (to and from the keypad).</li><li>• Provides a delayed alarm (using the programmed entry 1 time) if the entry/exit zone is faulted first. Otherwise this zone type gives an instant alarm.</li><li>• Active when the panel is armed in the Away mode.</li><li>• Bypassed automatically when the panel is armed in the Stay or Instant modes; if armed in Night-Stay mode, zones assigned to zone list 05 (night-stay zone list) are not bypassed when system armed in Night-Stay mode.</li></ul>
<b>Type 05 Trouble by Day/ Alarm by Night</b>	<ul style="list-style-type: none"><li>• Assign to a zone that contains a foil-protected door or window (such as in a store), or to a zone covering a sensitive area such as a stock room, drug supply room, etc.</li><li>• Can also be used on a sensor or contact in an area where immediate notification of an entry is desired.</li><li>• Provides an instant alarm if faulted when armed in the Away, Stay, Night-Stay, Instant or Maximum (night) modes.</li><li>• During the disarmed state (day), the system will provide a latched trouble sounding from the keypad (and a central station report, if desired).</li></ul>

<b>Type 06 24-hour Silent Alarm</b>	<ul style="list-style-type: none"> <li>• Usually assigned to a zone containing an emergency button.</li> <li>• Sends a report to the central station but provides no keypad display or sounding.</li> </ul>
<b>Type 07 24-hour Audible Alarm</b>	<ul style="list-style-type: none"> <li>• Assign to a zone that has an emergency button.</li> <li>• Sends a report to the central station, and provides an alarm sound at the keypad, and an audible external alarm.</li> </ul>
<b>Type 08 24-hour Auxiliary Alarm</b>	<ul style="list-style-type: none"> <li>• Assign to a zone containing an emergency button, or to a zone containing monitoring devices such as water or temperature sensors.</li> <li>• Sends a report to the central station and provides an alarm sound at the keypad. (No bell output is provided.)</li> </ul>
<b>Type 09 Supervised Fire</b>	<ul style="list-style-type: none"> <li>• Provides a fire alarm on short circuit and a trouble condition on open circuit. A fire alarm produces a pulsing bell output.</li> <li>• This zone type is always active and cannot be bypassed.</li> </ul>
<b>Type 10 Interior w/Delay</b>	<ul style="list-style-type: none"> <li>• Provides entry delay (using the programmed entry time), if tripped when the panel is armed in the Away mode.</li> <li>• Entry Delay 1 begins whenever sensors in this zone are violated, regardless of whether or not an entry/exit delay zone was tripped first.</li> <li>• Bypassed when the panel is armed in the Stay or Instant modes; if armed in Night-Stay mode, zones assigned to zone list 05 (night-stay zone list) are not bypassed when system armed in Night-Stay mode.</li> </ul>
<b>Type 12 Monitor Zone</b>	<ul style="list-style-type: none"> <li>• Works as a dynamic monitor of a zone fault/trouble (not alarm). In the case of a short/open, the message, "*ALARM*-24 Hr. Non-Burg. -#XXX " (where XXX is the zone number) will be sent to the Central Station. The system keypad will display a "check" message indicating the appropriate zone (but keypad beeping does not occur). Upon restoral of the zone, the message, "*RESTORE*-24 Hr. Non-Burg. -#XXX " will be sent to the Central Station.</li> <li>• The "check" message will automatically disappear from the keypad dynamically, when the zone restores; a user code + off sequence is not needed to reset the zone.</li> <li>• Faults of this zone type are independent of the system, and can exist at the time of arming without interference.</li> <li>• Since this is a "trouble" zone type, do not use this zone type with relays set to activate upon "alarm."</li> </ul>
<b>Type 14 24 Hour Carbon Monoxide Monitor</b>	<ul style="list-style-type: none"> <li>• Assigned to any zone with a carbon monoxide detector.</li> <li>• The bell output will pulse when this zone type is alarmed.</li> <li>• Always active and cannot be bypassed.</li> </ul>
<b>Type 15 24 Hour Medical/Personal Emergency</b>	<ul style="list-style-type: none"> <li>• Usually assigned to a zone containing an emergency button.</li> <li>• Sends a report to the central station (Contact ID event code "100") and provides an alarm sound at the keypad (no bell output is provided).</li> <li>• UL installations: may not use this zone type in UL installations.</li> </ul>
<b>Type 16 Fire w/Verification</b>	<ul style="list-style-type: none"> <li>• Provides a fire alarm when zone is shorted, but only after alarm verified.</li> <li>• System verifies alarm by resetting zones for 12 seconds after short is detected. A subsequent short circuit within 90 seconds triggers fire alarm.</li> <li>• Provides a trouble response when zone is open.</li> </ul>
<b>Type 20 Arm-Stay (BR only)</b>	<ul style="list-style-type: none"> <li>• Arms the system in Stay mode when the zone is activated.</li> <li>• Pushbutton units send the user number to the central station when arming or disarming.</li> <li>• User number for button must be assigned.</li> </ul>
<b>Type 21 Arm-Away (BR only)</b>	<ul style="list-style-type: none"> <li>• Arms the system in Away mode when the zone is activated.</li> <li>• Pushbutton units send the user number to the central station when arming or disarming.</li> <li>• User number for button must be assigned.</li> </ul>
<b>Type 22 Disarm (BR only)</b>	<ul style="list-style-type: none"> <li>• Disarms the system when the zone is activated.</li> <li>• User number for button must be assigned.</li> </ul>
<b>Type 23 * No Alarm Response</b>	<ul style="list-style-type: none"> <li>• Can be used on a zone when an output relay action is desired, but with no accompanying alarm (e.g., lobby door access).</li> </ul>

\* The system can still be armed when these zone types are in a faulted condition.

<b>Type 24 Silent Burglary</b>	<ul style="list-style-type: none"> <li>• Usually assigned to all sensors or contacts on exterior doors and windows where bells and/or sirens are NOT desired.</li> <li>• Provides an instant alarm, with NO audible indication at any keypad or external sounder, if the zone is faulted when the system is armed in the Away, Stay, Instant, or Maximum modes.</li> <li>• A report is sent to the central station.</li> </ul>
<b>Type 76 Arm-Maximum (BR only)</b>	<ul style="list-style-type: none"> <li>• Arms the system in Maximum mode when the zone is activated.</li> <li>• Pushbutton units send the user number to the central station when arming or disarming.</li> <li>• User number for button must be assigned.</li> </ul>
<b>Type 77 Keyswitch</b>	<ul style="list-style-type: none"> <li>• Assign to zone wired to a keyswitch.</li> <li>• Do not use devices assigned as input type “BR” with this zone type.</li> </ul>
<b>Type 81 AAV Monitor Zone</b>	<ul style="list-style-type: none"> <li>• Assign to zone connected to AAV module.</li> <li>• Monitors 2-way voice sessions as follows: <ul style="list-style-type: none"> <li>- When the zone is faulted, all alarm sounding and dialer reporting stops, except for fire alarms, which immediately terminate the voice session and cause a fire report to be sent.</li> <li>- When the zone is restored (session ended), sounding resumes (if bell timeout has not expired) and reports that were stopped are sent.</li> </ul> </li> </ul>
<b>Types 90-93 Configurable</b>	Allows for various custom responses. Options include response to entry/exit delays, response opens/shorts, types of alarm/trouble sounding, dial delay, and unique Contact ID report codes. Types 92 and 93 can only be programmed via downloader. UL installations: Zone Types 90 -93 may not be used as fire or burglar alarm zones on fire or UL burglar alarm installations.

**NOTE:** All of the zone types described are available for the wireless portion of the system, if used.

## Mechanics of Programming

### To program the system from a keypad:

- You must use a 2-line Alpha display keypad.
- Both partitions must be disarmed.

### Data Field Programming Procedures

Task	Procedure
Entering Program Mode	A) Press both [*] and [#] at the same time within 50 seconds after power is applied to the control, OR B) After power-up, enter Installer code + 8 0 0 (long beep indicates one of the partitions is armed and system cannot enter program mode). (method “B” is disabled if you exit the program mode using *98; also, Installer code is automatically disabled 4 hours after power-up)
Go to a Data Field	Press [*] + [Field Number] (for example, *21). A display of “EE” or “Entry Error” means you have entered a nonexistent field. Simply re-enter [*] plus a valid field number.
Entering Data	When the desired field number appears, simply enter the digits required. The keypad beeps three times after the last digit is entered and automatically displays the next data field in sequence. If entering less than the maximum digits available (e.g., phone number field), enter the desired digits, then press [*] and the next data field number to be programmed to end the entry.
Review a Data Field	Press [#] + [Field Number]. Field’s data is displayed, but no changes can be made.
Deleting an Entry	Press [*] + [Field No.] + [*] (applies only to phone number, account number, and pager character fields).

### Interactive Mode Programming (\*56, \*57, \*58, \*79, \*80, \*81, \*82)

Entering Interactive Mode	Press [*] + [Interactive Mode No.] (for example, *56) while in Program Mode. The Alpha display keypad will display the first of a series of prompts requesting entries. After making the appropriate entry, press the [*] key to accept the entry and continue to the next prompt.
---------------------------	---

**Loading Factory Defaults/Initializing for Download**

To Load Default Entries	Press *97 while in Program Mode. This resets all data fields to the default values shown on the Program Form. Use *97 only if you wish to return to the original factory-programmed defaults.
To Initialize Download ID	Press *96 while in Program Mode. This initializes the system for downloading and resets all the subscriber account numbers and CSID.

Do not press \*97 to load defaults if any programming has been done previously—data already programmed into the system will be changed!

**Exiting the Programming Mode (see Automatic Upload Note below)**

Prevent installer code reentry	Press *98. Exits Programming Mode and prevents re-entry by: Installer Code + [8] + [0] + [0]. To enter the programming mode if * 98 was used to exit, you must first power the system down. Then power up again, and press [*] and [#] at the same time, within 50 seconds of powering up, UNLESS Local Lockout is enabled (field *91). If so, re-entry to programming mode is permitted <i>only</i> by Installer code + [ 8] + [0] + [0].
Allow installer code reentry	Press *99. Exits Programming Mode and allows re-entry by: Installer Code + [ 8] + [0] + [0] or by: Pressing [*] and [#] at the same time, within 50 seconds of power-up. <b>NOTE:</b> Installer code is automatically disabled 4 hours after power-up.

**AUTOMATIC UPLOAD NOTE:** After exiting program mode, the control automatically initiates a download session and uploads all programming information. After a successful upload (alpha keypad displays “Upload Completed”), the following fields are locked and are no longer accessible via local programming mode: \*20 Installer Code, \*40-\*46 Telephone and Account Numbers, and \*94 Download Phone Number. However, these fields are accessible by the downloader.

To stop the upload, press [#] + [0] within 30 seconds of exiting program mode.

**Table of Device Addresses**

This Device	Uses Address	Reports as†	Enabled By...
RF Receiver	00	100	*56 zone programming: input device type entry
AUI 1	01	101	automatic if AUI enable field *189 enabled for AUI 1
AUI 2	02	102	automatic if AUI enable field *189 enabled for AUI 2
Long Range Radio	03	103	automatic if output to long range radio field *29 enabled
FA4286 Voice Module	04	104	automatic if phone module access code field *28 enabled
Zone Expanders (4219/4229):			*56 zone programming: input device type, entry 2, then:
module 1 (for zones 09 - 16)	07	107	automatic if zone no. 9-16 entered as AW type or relay assigned
module 2 (for zones 17 - 24)	08	108	automatic if zone no. 17-24 entered as AW type or relay assigned
module 3 (for zones 25 - 32)	09	109	automatic if zone no. 25-32 entered as AW type or relay assigned
module 4 zones 33 - 40	10	110	automatic if zone no. 33-40 entered as AW type or relay assigned
module 5 zones 41 - 48	11	111	automatic if zone no. 41-48 entered as AW type or relay assigned
Relay Modules (4204):			*79 output device programming: device address prompt:
module 1	12	112	entered at device address prompt
module 2	13	113	entered at device address prompt
module 3	14	114	entered at device address prompt
module 4	15	115	entered at device address prompt
Keypads:			data field programming as listed below:
keypad 1	16	n/a	always enabled for partition 1, all sounds enabled.
keypad 2	17	n/a	data field *190
keypad 3	18	n/a	data field *191
keypad 4	19	n/a	data field *192
keypad 5	20	n/a	data field *193
keypad 6	21	n/a	data field *194
keypad 7	22	n/a	data field *195
keypad 8	23	n/a	data field *196
5800TM Module	28	n/a	automatic

† Addressable devices are identified by “1” plus the device address when reporting. Enter a report code for zone 91 to enable addressable device reporting (default = reports enabled). See field \*199 for addressable device (ECP) 3-digit/2-digit identification keypad display options.

# Data Field Programming

## About Data Field Programming

The following pages list this control's data fields in numerical order. Field numbers are listed in the left column followed by a "Title and Data Entries column," which lists the valid entries for each field. Experienced installers can simply follow this column when programming the data fields. The "Explanation" column provides explanatory information and special notes where applicable.

## Programming Data Fields

Data field programming involves making the appropriate entries for each of the data fields. Start Data Field programming by entering the installer code + 8 + 0 + 0.

**NOTE:** The following fields will not be accessible after the automatic upload that occurs when you exit program mode: \*20 Installer Code, \*40-\*46 Telephone and Account Numbers, and \*94 Download Phone Number. See "Automatic Upload" note in *Mechanics of Programming—Exiting Program Mode* section.

**SIA Guidelines:** Notes in certain fields give instructions for programming the FA168CP-GP for False Alarm Reduction.

## System Setup Fields (\*20 – \*29)

FIELD	TITLE and DATA ENTRIES	EXPLANATION
<b>*20</b>	<b>Installer Code</b> Enter 4 digits, 0-9	The Installer Code is used to assign the 4-digit Master Security Code. See "Master Code" in the <i>System Operation</i> section for procedure. <b>NOTE:</b> Installer's code is automatically disabled 4 hours after power-up. Powering down then powering up again will re-enable the installer code for another 4 hours.
<b>*21</b>	<b>Quick Arm Enable</b> 0 = do not allow quick arm 1 = allow quick arm	If enabled, a user code is not needed to arm the system. Instead, users can press the [#] key followed by an arming key to arm the system. However, the user code is always needed to disarm the system.
<b>*22</b>	<b>RF Jam Option</b> 0 = no RF jam detection 1 = send RF jam report	If enabled, a report is sent if the system detects an RF jamming signal. UL installations must be 1 if wireless devices are used.
<b>*23</b>	<b>Quick (Forced) Bypass</b> 0 = no forced bypass 1 = automatically bypass all faulted zones	All zones bypassed by this function will be displayed after the bypass is initiated. UL installations must be 0 (no forced bypass)
<b>*24</b>	<b>RF House ID Code</b> 00 = disable all wireless keypad usage 01-31 = House ID for partition 1, 2 and common	The House ID identifies receivers and wireless keypads. If a 5827 or 5827BD Wireless Keypad or 5804BD Transmitter is being used, a House ID code <b>must</b> be entered, and the keypad should be set to the same House ID. You can assign RF house ID for each partition.
<b>*26</b>	<b>Chime By Zone (Zone List 3)</b> 0 = no zone list (chimes on fault of any entry/exit or perimeter zone when chime mode on) 1 = use zone list (chimes on fault of specific zones programmed in relay zone list 3 when Chime mode on)	If enabled, you can define the specific zones intended to chime when faulted while the system is in Chime mode. Use zone list 3 to assign these zones (see *81 <i>Zone List Programming</i> section for details).
<b>*27</b>	<b>Powerline Carrier Device (X-10) House ID</b> 0 = A      6 = G      # + 11 = L 1 = B      7 = H      # + 12 = M 2 = C      8 = I      # + 13 = N 3 = D      9 = J      # + 14 = O 4 = E      # + 10 = K    # + 15 = P 5 = F	Powerline Carrier devices require a House ID, identified in this field. Program Powerline Carrier devices in interactive modes *79, *80 and *81. Not intended for fire or UL installations.
<b>*28</b>	<b>Access Code for Phone Module</b> 1-9 = first digit of access code * or # = second digit of access code (enter # +11 for "*", or # +12 for "#")	You need to assign a 2-digit access code for the FA4285/FA4286 Phone Module, if used. Example: If desired access code is 7* , 7 is the first entry, and [#] + 11 (for *) is the second entry. <b>NOTE:</b> A "0" in either digit disables the phone module. Must be "00" for UL Commercial Burglar Alarm installations.

FIELD	TITLE and DATA ENTRIES	EXPLANATION
<b>*29</b>	<b>Long Range Radio Output</b> 0 = not used 1 = using Long Range Radio output	If selected, all messages programmed to go to the primary telephone line receiver will also be sent to the connected 7720PLUS, 7820, 7835, or 7845 Radio (sent in Contact ID format). The data line is supervised as well as certain functions in the radio. If communication is lost or a trouble develops, an attempt will be made to send a message via both radio and telephone to the central station. Program the radio for device address 3.

**Zone Sounds & Timing (\*31–\*39)**

FIELD	TITLE and DATA ENTRIES	EXPLANATION
<b>*31</b>	<b>Single Alarm Sounding Per Zone</b> (per armed period) 0 = no limit on alarm sounding per zone 1 = limit alarm sounding to once per arming period for a given zone	Make desired selection.
<b>*32</b>	<b>Fire Alarm Sounder Timeout</b> 0 = yes; fire sounder timeout after time programmed in field *33 1 = no fire sounder timeout; continue sounding until manually turned off	This control complies with NFPA requirements for temporal pulse sounding of fire notification appliances. Temporal pulse sounding for a fire alarm consists of the following: 3 pulses – pause – 3 pulses – pause – 3 pulses. UL fire alarm installations: must be 1.
<b>*33</b>	<b>Alarm Sounder Timeout</b> 0 = No timeout           3 = 12 min 1 = 4 min                 4 = 16 min 2 = 8 min	This field determines whether the external sounder will shut off after time allotted, or continue until manually turned off. UL installations: For residential fire alarm installation, must be set for a minimum of 4 min (option 1); for UL Commercial Burglary installations, must be minimum of 16 min (option 4).
<b>*34</b>	<b>Exit Delay</b> 00 - 96 = 0 - 96 seconds 97 = 120 seconds 98 = 180 seconds 99 = 240 seconds	The system waits the time entered before arming entry/exit zones. If the entry/exit door is left open after this time expires, an alarm will occur. Common zones use same delay as partition 1. UL installations: For UL Commercial Burglar Alarm (Grade AA) and UL Residential Burglar Alarm installations with line security, total exit time must not exceed 60 seconds. For UL Burglar Alarm installations without line security (Grade A), total exit time must not exceed 120 seconds. SIA Installations: minimum exit delay is 45 seconds
<b>*35</b>	<b>Entry Delay 1</b> 00 - 96 = 0 - 96 seconds 97 = 120 seconds 98 = 180 seconds 99 = 240 seconds	Upon entering, the system must be disarmed before the time entered expires, otherwise it sounds an alarm. Common zones use same delay as partition 1. UL installations: For UL Residential Burglary Alarm installations, must be set for a maximum of 30 seconds; entry delay plus dial delay should not exceed 1 min. For UL Commercial Burglar Alarm, total entry delay may not exceed 45 seconds. SIA Installations: minimum entry delay is 30 seconds
<b>*36</b>	<b>Entry Delay 2</b>	See *35 above for entries and explanation.
<b>*37</b>	<b>Audible Exit Warning</b> 0 = no; 1 = yes	Warning sound consists of slow continuous beeps until last 10 seconds, then it changes to fast beeps. Sound ends when exit time expires. SIA Installations: must be enabled (enter 1)
<b>*38</b>	<b>Confirmation Of Arming/Disarming Ding</b> 0 = no ding 1 = confirmation ding after arming/disarming system 2 = confirmation ding after arming/disarming from RF button or RF keypad only	Confirmation of arming is 1/2 second external sounder “ding.” Confirmation of disarming is two short dings. If “1” selected, ding occurs when closing/opening report is sent, or at the end of Exit Delay. If “2” selected, ding occurs upon reception of the wireless arming/disarming command. UL installations: must be “1” for UL Commercial Burglar Alarm installations.
<b>*39</b>	<b>Power-Up In Previous State</b> 0 = always power-up in a disarmed state 1 = assume the system status prior to power down	When the system powers up armed, an alarm will occur 1 minute after arming if a zone is faulted. Note that if the previous state was armed Away or Stay, the system will not respond to sensor changes for 1 minute, which allows time for sensors such as PIRs to stabilize. UL installations: must be 1 (power-up in previous state) SIA Guidelines: must be 1

## Dialer Programming (\*40 – \*50)

FIELD	TITLE and DATA ENTRIES	EXPLANATION												
<b>*40</b>	<b>PABX Access Code or Call Waiting Disable</b> Enter up to 6 digits if PABX is needed to access an outside line. Do not fill unused spaces. 0–9, # + 11 for '*', # + 12 for '#', # + 13 for a pause (2 seconds)	To clear entries from field, press *40*. If fewer than 6 digits need to be entered, exit by pressing [*], which advances to the next field.  <b>Call Waiting:</b> If the subscriber's phone service has "call waiting" (and is not using PABX), enter "*70" ("# + 11") plus "# + 13" (pause) as the PABX entry to disable "call waiting" during control panel calls. If the subscriber does not have "call waiting" and is not using PABX, make no entry in this field. <b>NOTES:</b> 1. The call waiting disable feature cannot be used on a PABX line. 2. Using Call Waiting Disable on a non-call waiting line will prevent successful communication to the central station.												
<b>*41</b>	<b>Primary Phone No.</b> Enter up to 20 digits. Do not fill unused spaces. 0–9, # + 11 for '*', # + 12 for '#', # + 13 for a pause (2 seconds)	If you enter fewer than 20 digits, exit by pressing [*]. To clear entries from field, press *41*. <b>NOTE:</b> Backup reporting (in which 8 calls are made to the secondary phone number if no kissoff is received after 8 attempts to the primary number) is automatic only if there is a secondary phone number (field *42). <b>Pager Report Note:</b> In order for pager reports to be sent to the pager phone number, you must also enter a primary (field *41) or secondary (field *42) phone number.												
<b>*42</b>	<b>Secondary Phone No.</b> Enter up to 20 digits. Do not fill unused spaces. 0–9, # + 11 for '*', # + 12 for '#', # + 13 for a pause (2 seconds)	If you enter fewer than 20 digits, exit by pressing [*]. To clear entries from field, press *42*. See backup reporting note in field *41. See Pager Report Note in field *41.												
<b>*43</b>	<b>Part. 1 Primary Subs. Acct. No.</b> Enter digits 0–9; # + 11 for B, # + 12 for C, # + 13 for D, # + 14 for E, # + 15 for F.	To clear entries from field, press *43*.												
<b>*44</b>	<b>Part. 1 Secondary Subs. Acct. No.</b> Enter digits 0–9; # + 11 for B, # + 12 for C, # + 13 for D, # + 14 for E, # + 15 for F.	To clear entries from field, press *44*.												
<b>*45</b>	<b>Part. 2 Primary Subs. Acct. No.</b> Enter digits 0–9; # + 11 for B, # + 12 for C, # + 13 for D, # + 14 for E, # + 15 for F.	To clear entries from field, press *45*.												
<b>*46</b>	<b>Part. 2 Secondary Subs. Acct. No.</b> Enter digits 0–9; # + 11 for B, # + 12 for C, # + 13 for D, # + 14 for E, # + 15 for F.	To clear entries from field, press *46*.												
<b>*47</b>	<b>Phone System Select</b> If Central Station Receiver <b>is not</b> on WATS line: 0 = Pulse Dial; 1 = Tone Dial If Central Station Receiver <b>is</b> on WATS line: 2 = Pulse Dial; 3 = Tone Dial	Select the type of telephone service.												
<b>*48</b>	<b>Report Format (Primary/Secondary)</b> 2 = 4+2 ADEMCO L/S STANDARD 7 = ADEMCO Contact ID@ 4-digit Format	Select report format for primary and secondary phone numbers.												
<b>*49</b>	<b>Split/Dual Reporting</b> 0 = standard/backup reporting only (all reports only to primary unless unsuccessful, then will attempt secondary) 1 - 5 = see table to right	<table border="1"> <thead> <tr> <th>To Primary No.</th> <th>To Secondary No.</th> </tr> </thead> <tbody> <tr> <td>1 = alarms, restore, cancel</td> <td>others</td> </tr> <tr> <td>2 = all except open/close, test</td> <td>open/close, test</td> </tr> <tr> <td>3 = alarms, restore, cancel</td> <td>all</td> </tr> <tr> <td>4 = all except open/close, test</td> <td>all</td> </tr> <tr> <td>5 = all</td> <td>all</td> </tr> </tbody> </table>	To Primary No.	To Secondary No.	1 = alarms, restore, cancel	others	2 = all except open/close, test	open/close, test	3 = alarms, restore, cancel	all	4 = all except open/close, test	all	5 = all	all
To Primary No.	To Secondary No.													
1 = alarms, restore, cancel	others													
2 = all except open/close, test	open/close, test													
3 = alarms, restore, cancel	all													
4 = all except open/close, test	all													
5 = all	all													
<b>*50</b>	<b>Burglary Dialer Delay</b> 0 = no dial delay 1 = 15 seconds 2 = 30 seconds 3 = 45 seconds	Provides delay of "BURGLARY ALARM" report to the central station, which allows time for the subscriber to avoid a false alarm transmission. This delay does not apply to zone type 24 alarms (silent burglary) or to 24-hour zone types 6, 7, and 8 (silent panic, audible alarm, auxiliary alarm), which are always sent as soon as they occur. UL: must be "0" SIA Installations: delay must be minimum of 30 seconds												

FIELD	TITLE and DATA ENTRIES	EXPLANATION
<b>*54</b>	<b>Dynamic Signaling Delay</b> 0 = disabled (both signals sent) 1–15 = entry times a 15-second delay. e.g., 1 = 15 seconds, 2 = 30 seconds, etc.	Intended for use with Long Range Radio reporting. This field lets you select the time the panel should wait for acknowledgment from the first reporting destination (see *55) before it attempts to send a message to the second destination. Delays can be selected from 0 to 225 seconds, in 15-second increments. This delay is per message. If "0" is entered in this field, the control panel will send redundant reports to both Primary Dialer and LRR.  UL Installations: For Fire Alarm and UL Burglar Alarm installations <b>without Line Security (Grade A)</b> , the maximum Dynamic Signaling Delay must be no more than 15 seconds.  For UL Burglar Alarm installations <b>with Line Security (Grade AA)</b> , Dynamic Signaling Delay must be "0". The reports will be sent to both the dialer and the LRR.
<b>*55</b>	<b>Dynamic Signaling Priority</b> 0 = Primary dialer first; 1 = Long Range Radio (LRR) first.  <div style="border: 1px solid black; padding: 5px; width: fit-content;">UL Installations: For UL Commercial Burglary installations that use a DACT and LRR, the DACT must be programmed for priority (option "0").</div>	Intended for use with Long Range Radio reporting. You must also enable field *29, OUTPUT TO LONG RANGE RADIO. Select the initial reporting destination for messages as follows: Primary Dialer First selected (0): <ul style="list-style-type: none"> <li>• If acknowledged before delay expires (see *54), then message will not be sent to LRR.</li> <li>• If not acknowledged before delay expires, then message is sent to both the Primary Phone No. and LRR.</li> </ul> Long Range Radio First selected (1): <ul style="list-style-type: none"> <li>• If acknowledged before delay expires, then message will not be sent to the primary dialer.</li> <li>• If not acknowledged before delay expires, then message is sent to both the Primary Phone No. and LRR.</li> </ul>
<b>*56</b>	<b>Zone Programming Menu Mode</b>	Use this menu mode to program zone information. See Zone Programming section for procedures.
<b>*57</b>	<b>Function Key Menu Mode</b>	Use this menu mode to program keypad function keys. See Function Key section for procedures.
<b>*58</b>	<b>Expert Zone Programming Menu Mode</b>	This menu mode can be used to quickly program zone information, but is recommended only for those already familiar with *56 menu mode. See Zone Programming section for procedures.

### System Status Report and Restore Codes

Zone report codes are programmed using interactive \*56 or \*58 Zone Programming modes, while system status (non-alarm) codes and restore codes are entered in the following data fields.

UL installations: Program fields \*59 - \*68, \*70 - \*76, \*89 as required by the applicable UL Standards shown in each field's description.

**Contact ID® Reporting:** Enter any digit (other than "0") in the first box to enable the zone to report. Entries in the second boxes will be ignored.

FIELD	TITLE and DATA ENTRIES	EXPLANATION
<b>*59</b>	<b>Exit Error Report Code</b> 0 = no report non-zero = send report	After arming the system, entry/exit and interior zones remaining open after exit delay expires cause an alarm sound at the keypad and external sounder (keypad displays "EXIT ALARM"), and entry delay begins. Disarming before the end of the entry delay stops alarm sounding and no message is sent to the central station. The keypad displays "CA" (fixed-word) or "CANCELED ALARM" (alpha display).  If the system is not disarmed before entry delay expires, an "EXIT ALARM" message will be sent to the central station if Exit Error Report Code is enabled. The keypad will display "EA" (fixed-word) or "EXIT ALARM" (alpha display), and alarm sounding continues until the system is disarmed (or timeout occurs).  An Exit Alarm condition will also result if a fault occurs in an exit or interior zone within 2 minutes following the end of the exit delay, and an "EXIT ALARM" message will be sent to the central station  With Contact ID format, the message will contain the zone number and error code 374 ("ALARM-EXIT ERROR")



FIELD	TITLE and DATA ENTRIES	EXPLANATION
<b>*60</b>	<b>Trouble Report Code</b> 0 = no report 1st digit non-zero = send report	This will be sent if a zone has a trouble condition. UL: Required for UL commercial burglar alarm installations and required for residential fire alarm installations.
<b>*61</b>	<b>Bypass Report Code</b> 0 = no report 1st digit non-zero = send report	This will be sent when a zone is manually bypassed. UL: Required for UL commercial burglar alarm installations.
<b>*62</b>	<b>AC Loss Report Code</b> 0 = no report 1st digit non-zero = send report	Timing of this report is random with up to a 4-hour delay. If AC restores before the report goes out, there is no "AC RESTORE" report. UL: Required for UL commercial burglar alarm installations and required for residential fire alarm installations.
<b>*63</b>	<b>Low Bat Report Code</b> 0 = no report 1st digit non-zero = send report	Sent when a low-battery condition exists in the system's battery. UL: Required for UL commercial burglar alarm installations and required for residential fire alarm installations.
<b>*64</b>	<b>Test Report Code</b> 0 = no report 1st digit non-zero = send report	Sent periodically to test that the communicator and phone lines are operational. Frequency of report is set in Scheduling mode (event 11). <b>NOTE:</b> A test report is automatically set for schedule 32 when the system time is initially set, and the first report is sent 12 hours later; thereafter the test report is sent every 28 days. UL: Required for UL commercial burglar alarm installations and required for residential fire alarm installations.
<b>*65</b>	<b>Open Report Code</b> 0 = no report 1st digit non-zero = send report	This is sent upon disarming of the system in the selected partitions. UL: Required for UL commercial burglar alarm installations.
<b>*66</b>	<b>Arm Away/Stay Report Code</b> 0 = no report 1st digit non-zero = send report	This option allows for independent programming of Away and Stay reports for each partition, including the common lobby. <b>NOTE:</b> "OPEN" reports are not sent if the associated closing report is not enabled.
<b>*67</b>	<b>RF Trans. Low Batt. Report Code</b> 0 = no report 1st digit non-zero = send report	Sent when a wireless transmitter low-battery condition exists. UL installations: must be enabled if wireless devices are used.
<b>*68</b>	<b>Cancel Report Code</b> 0 = no report 1st digit non-zero = send report	This is sent upon disarming of the system after an alarm condition was reported.
<b>*70</b>	<b>Alarm Restore Report Code</b> 0 = no report non-zero = send report	Sent when an alarm zone is restored to its non-faulted condition. UL: Required for UL commercial burglar alarm installations and required for residential fire alarm installations.
<b>*71</b>	<b>Trouble Restore Report Code</b> 0 = no report 1st digit non-zero = send report	This is sent when a trouble in a zone is restored UL: Required for UL commercial burglar alarm installations.
<b>*72</b>	<b>Bypass Restore Report Code</b> 0 = no report 1st digit non-zero = send report	This is sent when a zone that has been bypassed is unbypassed. UL: Required for UL commercial burglar alarm installations.
<b>*73</b>	<b>AC Restore Report Code</b> 0 = no report 1st digit non-zero = send report	Sent when AC power has been restored after an AC power outage. UL: Required for UL commercial burglar alarm installations and required for residential fire alarm installations.
<b>*74</b>	<b>Low Bat Restore Report Code</b> 0 = no report 1st digit non-zero = send report	Sent when a system low-battery condition is restored to normal. UL: Required for UL commercial burglar alarm installations and required for residential fire alarm installations.
<b>*75</b>	<b>RF Xmtr Low Batt. Restore Code</b> 0 = no report 1st digit non-zero = send report	Sent when a transmitter's low battery condition is restored (i.e., new battery installed). UL installations: must be enabled if wireless devices are used. Required for UL commercial burglar alarm installations and required for residential fire alarm installations.
<b>*76</b>	<b>Test Restore Report Code</b> 0 = no report 1st digit non-zero = send report	This is sent when the Test mode is exited. UL: Required for UL commercial burglar alarm installations and required for residential fire alarm installations.

Miscellaneous System Fields

FIELD	TITLE and DATA ENTRIES	EXPLANATION
<b>*77</b>	<b>Daylight Saving Time Start/End Month</b> 0 = Disabled      4 = April 1 = Jan            # + 10 = Oct 2 = Feb            # + 11 = Nov 3 = Mar            # + 12 = Dec	Enter the start and end month for daylight savings time, if applicable to the region.
<b>*78</b>	<b>Daylight Saving Time Start/End Weekend</b> 0 = disabled      4 = fourth 1 = first           5 = last 2 = second        6 = next to last 3 = third          7 = third to last	Enter the start and end weekend for daylight savings time, if applicable to the region.
<b>*79</b>	<b>Output Device Mapping Menu Mode</b>	Use this menu mode to enter output devices/powerline carrier devices into the system. See Output Device Programming section for procedures.
<b>*80</b>	<b>Output Programming Menu Mode</b>	Use this menu mode to define output functions for use with output devices/powerline carrier devices. See Output Programming section for procedures.
<b>*81</b>	<b>Zone List Programming Menu Mode</b>	Use the menu mode to define zone lists. See Zone List Programming section.
<b>*82</b>	<b>Alpha Descriptor Programming Menu Mode</b>	Use this menu mode to assign alpha descriptors to zones and/or create partition descriptors.
<b>*83</b>	<b>Time Zone Selection</b> 0 = Eastern      2 = Mountain 1 = Central      3 = Pacific	Select the appropriate time zone in which the control is installed. This setting provides proper downloader time synchronization if downloading from a different time zone.
<b>*84</b>	<b>Auto-Stay Arm</b> 0 = no 1 = partition 1 only 2 = partition 2 only 3 = both partitions	If enabled, the system will automatically change AWAY/MAXIMUM modes to STAY/INSTANT modes respectively if the entry/exit door <b>is not</b> opened and closed within the exit delay time after a user arms in AWAY mode from a wired keypad (non-RF device). An Opening report followed by an Armed Stay report is sent to the Central Station.  If the door <b>is</b> opened and closed within the exit delay period, the system remains in AWAY mode.  Any RF device that arms the system AWAY overrides this feature and the system remains armed in the AWAY mode.
<b>*85</b>	<b>Cross Zone Timer</b> 0 = 15 secs      6 = 2-1/2 min    #+12 = 8 min 1 = 30 secs      7 = 3 min        #+13 = 10 min 2 = 45 secs      8 = 4 min        #+14 = 12 min 3 = 60 secs      9 = 5 min        #+15 = 15 min 4 = 90 secs      #+10 = 6 min 5 = 2 min        #+11 = 7 min	Sets the maximum amount of time in which two cross zones must be tripped in an armed system to send an alarm message to the Central Station. If only one cross zone is tripped during this time, a trouble message (CID code 380) for that zone is sent to the Central Station.  Assign cross zone pairs in zone list 4. This option not for use in UL installations.
<b>*86</b>	<b>Cancel Verify Keypad Display</b> 0 = no 1 = yes	When enabled (1 = yes), this feature causes a <b>"CANCELED ALARM"</b> display on the LCD keypad under the following conditions: <ul style="list-style-type: none"> <li>• After the kissoff of the cancel message to the Central Station, indicating a successful transmission.</li> <li>• When an alarm is successfully canceled before the Central Station received the Alarm message. E.g., if an alarm is incorrectly triggered and the user presses code + OFF before the dial delay time has expired, the message will never go out to the CS.</li> <li>• When the Cancel report is not enabled and the system is disarmed:                             <ol style="list-style-type: none"> <li>a. <b>before</b> dialer delay expires (alarm report not sent) message "Canceled Alarm" is displayed.</li> <li>b. <b>after</b> dialer delay expires message "Canceled Alarm" is not displayed.</li> </ol> </li> </ul>

**NOTE:** Cancel display is automatically disabled if field \*199 ECP FAIL DISPLAY is set to "1" (2-digit display).

FIELD	TITLE and DATA ENTRIES	EXPLANATION
<b>*87</b>	<b>Misc. Fault Delay Time</b> 0 = 15 secs    6 = 2-1/2 min    #+12 = 8 min 1 = 30 secs    7 = 3 min    #+13 = 10 min 2 = 45 secs    8 = 4 min    #+14 = 12 min 3 = 60 secs    9 = 5 min    #+15 = 15 min 4 = 90 secs    #+10 = 6 min 5 = 2 min    #+11 = 7 min	Used with zones assigned to a configurable zone type with fault delay on (configurable zone type digit "6"), and sets a zone response time of 15 seconds to 15 min. It can be assigned to zones with sensors that provide a trouble indication when an oil tank is low, or similar applications for critical condition monitoring where a non-alarm response is desired. UL: May only be used on non-burglar alarm and non-fire alarm zones when used on a fire and/or UL burglar alarm installation.
<b>*89</b>	<b>Event Log Full Report Code</b> 0 = no report 1st digit non-zero = send report	If an Event Logging selection is made in field *90, a message can be sent to the central station receiver when the log is 80% full. If the log becomes full, new messages overwrite the oldest messages in the log.
<b>*90</b>	<b>Event Log Enables</b> 0 = no event logging 1 = log Alarm/Alarm Restore 2 = log Trouble/Trouble Restore 4 = log Bypass/Bypass Restore 8 = log Open/Close x = log combination of events (add value of entries)	This system has the ability to record various events in a history log (up to 100 events). At any time, the downloader operator can then upload the log and view or print out all or selected categories of the log. The downloader operator can also clear the log. Event log can also be viewed at an alpha keypad. The display/printout at the central station will show the date, time, event, and description of the occurrences. Data Entry Example: To select Alarm/Alarm Restore" and "Open/Close", enter 9 (1+ 8); to select all events, enter #15.
<b>*91</b>	<b>Option Selection</b> 0 = none 1 = Local Lockout 2 = Sounder Delay 4 = Using Audio Alarm Verification (AAV) unit 8 = Enable Exit delay restart ††	Select the desired options by adding the values of each desired option. If Local Lockout enabled: When exiting program mode with *98, can only reenter program mode by installer code + 800. Sounder Delay: If enabled, delays external sounding by 15-seconds. ††"Exit Delay Restart/reset" option allows use of the [*] key to restart the exit delay at any time when the system is armed STAY or INSTANT. This feature also enables automatic exit delay reset, which resets exit delay if the entry/exit door is re-opened and closed before exit delay time expires after arming AWAY. Automatic Exit Delay Reset occurs only once during an armed period.
	<p><b>UL</b> UL installations using the AAV feature must use the ADEMCO UVCM module (part of the ADEMCO UVS system). Exit Delay Restart/Reset must be disabled.</p> <p><b>FOR SIA INSTALLATIONS:</b> Exit delay should be enabled.</p> <p>Multiple choice example: for both AAV and Exit delay restart, enter # + 12 (4 + 8); for all (1 + 2 + 4 + 8), enter # + 15.</p>	<b>IMPORTANT:</b> AAV should not be used when Paging or Alarm Reports are sent to a secondary number unless the monitoring zone option is used (which pauses calls). Otherwise, the call to the secondary number by the communicator after the alarm report will prevent the AAV from taking control of the telephone line, and the AAV "Listen in" session cannot take place.
<b>*92</b>	<b>Phone Line Monitor Enable</b> <b>Entry 1–Timeout:</b> 0 = disabled 1-15 = 1 minute to 15 minutes respectively (2 = 2 min, 3 = 3 min, etc.; # + 10 = 10 min, # + 11 = 11 min, # + 12 = 12 min, # + 13 = 13 min, # + 14 = 14 min, # + 15 = 15 min) <b>Entry 2–Display/Sound:</b> 0 = keypad display when phone line is faulted. 1 = keypad display plus keypad trouble sound when line is faulted. Each partition turns off its own trouble sound. No automatic timeout. 2 = Same as "1" plus programmed output device STARTS. If either partition is armed, external sounder activates. External sounder will be turned off by normal bell timeout, or by security code plus OFF from either partition (it does not have to be the one that was armed).	<b>Entry 1:</b> Sets the length of time a phone line fault must remain after detected before the second digit option is activated. <b>Entry 2:</b> Selects the desired phone line fault response. Option 2 may be used even if a relay unit or Powerline carrier device is not connected to the control. Programmed Output Device must either be programmed to be STOPPED in field *80 or STOPPED by entry of [security code] + [#] + 8 + device number. Partition in *80 should be set to "0," for STOP.
	<p><b>UL</b> Field *92 must be enabled for fire alarm installations, UL commercial burglar alarm installations and UL residential burglar alarm installations.</p> <p>If the control unit is used on a UL commercial burglar alarm system which requires 2 methods of remote communication, then the control unit's DACT and the other method of signal transmission must monitor each other against communication failure and line fault. The fault must be received and annunciated within 200 seconds of its occurrence.</p>	
<b>*93</b>	<b>No. of Reports In Armed Period per Zone (Swinger Suppression)</b> 0 = unlimited number of reports 1 = 1 report pair per zone per armed period 2 = 2 report pairs per zone per armed period	This option can be used to limit the number of alarm/alarm restore message pairs per zone sent to the central station in an armed period.  SIA Installations: Must be set for option 1 or 2.

**\*94**     **Download Phone Number**  
 Enter up to 20 digits as follows: 0-9, # +11 for "\*", # + 12 for "#", # + 13 for a pause.

Enter the phone number of the downloading computer. Do not fill unused spaces. End field by entering \*. To clear entries from field, press \*94\*.

**\*95**     **Ring Count For Downloading**  
 0-15 = number of rings before control picks up phone line .

Refer to the chart below and program this field accordingly.

phone module	answer machine	down-loading	Set field *95 to...
yes	no	no	1-14 (not 0)
yes	yes	no	higher than number of rings set on answer machine (e.g., if ans. machine is 4 rings, set this field to 5). This allows access to the phone module if the answer machine is turned off.
yes	no	yes	1-14 (not 0)
yes	yes	yes	15 (bypasses answer machine <sup>†</sup> )
no	no	no	0
no	yes	no	0
no	no	yes	1-14
no	yes	yes	15

<sup>†</sup> **NOTE:** If "15" is entered to bypass an answering machine, and a FA4285/FA4286 Phone Module is included in the system, you should note the following:  
 When calling in from an off-premises phone, the user should make the initial call, allow 1 or 2 rings only, then hang up. The user should then call again. The phone module will now seize the line, and 2 long tones sound, followed by the usual voice prompt for the access code. If this procedure is not followed, phone module operation will not be possible.

**\*96**     **Command to Initialize CSID and Subscriber Account Number**

This is a command function, not a data field. Use this command, if necessary, to reset all subscriber account numbers and the internal CSID to the factory default values.

**\*97**     **Command to Reset System to Factory Default Values**

This is a command function, not a data field. Pressing \*97 resets all data fields to the factory default values (shown on the Program Form).  
**IMPORTANT:** Do not press \*97 to load defaults if any programming has been done previously—data already programmed into the system will be changed!

**\*98**     **Command to Exit Program Mode (with installer code lockout)**

Exits Programming Mode and prevents re-entry by: Installer Code + [8] + [0] + [0]. To enter the programming mode if \* 98 was used to exit, you must first power the system down. Then power up again, and press [\*] and [#] at the same time, within 50 seconds of powering up.

**\*99**     **Command to Exit Program Mode**

Exits Programming Mode and allows re-entry by: Installer Code + [ 8] + [0] + [0] or by: Pressing [\*] and [#] at the same time, within 50 seconds of power-up.

## Pager Programming Fields

FIELD	TITLE and DATA ENTRIES	EXPLANATION
<b>*160</b>	<b>Pager 1 Phone No.</b> Enter up to 20 digits	If you enter fewer than 20 digits, exit by pressing [*] and next field number. To clear entries from this field, press *160*.
<b>*161</b>	<b>Pager 1 Characters</b> Enter up to 16 characters	<p>Up to 16 optional characters may be sent as a prefix to the 7-digit system status code sent to Pager 1 (if used). Phone number in field *160 must have been entered. If fewer than 16 characters, exit by pressing [*] and next field number. To clear entries from this field, press *161*.</p> <p>For example, these optional 16 characters may be composed of the following:</p> <ul style="list-style-type: none"> <li>• PIN number (to identify a specific pager to the paging company)</li> <li>• Subscriber account number</li> <li>• * (enter # + 11 to send *)</li> <li>• # (enter # + 12 to send #)</li> <li>• Pause (enter # + 13 to allow a 2-second pause)*</li> <li>• Any special character(s) the end user may decide to transmit</li> </ul> <p>* Some paging systems require pause(s) before the prefix. The format for the 7-digit system status code is defined as follows: Pager Format: XXX-YYYY where: XXX = 3-digit event code: 911 = Alarm 811 = Trouble 101 = Opening (disarm) 102 = Closing (arm AWAY) YYYY = 4-digit user or zone number (depending on type of event). The first two digits must always be 00, and must be followed by the 2-digit user or zone number.</p> <p><i>Example 1.</i> Pager displays: 911-0004 This indicates that the system is reporting an alarm (911) caused by a fault in zone 4 (0004).</p> <p><i>Example 2.</i> Pager displays: 102-0005 This indicates that the system is reporting a closing-system arming (102) by User 5 (0005).</p>
<b>*162</b>	<b>Pager 1 Report Options</b>  0 = No reports sent 1 = Open/close for all users enabled to page† 4 = All alarms and troubles 5 = All alarms, troubles, and open/close for all users enabled to page 12 = Alarms and troubles for zones entered in zone list 9 13 = Alarms and troubles for zones listed in zone list 9 and open/close for all users enabled to page	<p>Enter the types of reports to be sent to Pager 1 for each partition.</p> <p><b>Pager Report Note:</b> In order for pager reports to be sent to the pager phone number, you must also enter a primary (field *41) or secondary (field *42) phone number.</p> <p>† Reports to pager only when arming (close)/disarming (open) from a keypad using a security code command; auto-arming/disarming, arming with assigned button, and keyswitch arming do not send pager messages.</p>
<b>*163</b>	<b>Pager 2 Phone No.</b> Enter up to 20 digits	If you enter fewer than 20 digits, exit by pressing [*] and next field number. To clear entries from this field, press *163*.
<b>*164</b>	<b>Pager 2 Characters</b> Enter up to 16 characters	See field *161 for explanation of entries. If fewer than 16 characters, exit by pressing [*] and next field number. To clear entries from this field, press *164*.
<b>*165</b>	<b>Pager 2 Report Options</b> see Pager 1 reports, field *162 for entries, except use zone list 10.	Enter the types of reports to be sent to Pager 2 for each partition.

FIELD	TITLE and DATA ENTRIES	EXPLANATION
<b>*166</b>	<b>Pager 3 Phone No.</b> Enter up to 20 digits	If you enter fewer than 20 digits, exit by pressing [*] and next field number. To clear entries from this field, press *166*.
<b>*167</b>	<b>Pager 3 Characters</b> Enter up to 16 characters	See field *161 for explanation of entries. If fewer than 16 characters, exit by pressing [*] and next field number. To clear entries from this field, press *167*.
<b>*168</b>	<b>Pager 3 Report Options</b> see Pager 1 reports, field *162 for entries, except use zone list 11.	Enter the types of reports to be sent to Pager 3 for each partition.
<b>*169</b>	<b>Pager 4 Phone No.</b> Enter up to 20 digits	If you enter fewer than 20 digits, exit by pressing [*] and next field number. To clear entries from this field, press *169*.
<b>*170</b>	<b>Pager 4 Characters</b> Enter up to 16 characters	See field *161 for explanation of entries. If fewer than 16 characters, exit by pressing [*] and next field number. To clear entries from this field, press *170*.
<b>*171</b>	<b>Pager 4 Report Options</b> see Pager 1 reports, field *162 for entries, except use zone list 12.	Enter the types of reports to be sent to Pager 4 for each partition.
<b>*172</b>	<b>Pager Delay Option for Alarms</b> 0 = none                    2 = 2 minutes 1 = 1 minute                3 = 3 minutes	This field determines the delay of alarm reports to the pager. This gives the Central Station enough time to verify the alarm report that it received, before the dialer attempts to dial the pager. This delay is for ALL pagers in the system.

### Miscellaneous System Fields

<b>*174</b>	<b>Clean Me Option</b> 0 = disable 1 = enable	This is a maintenance feature for ESL 2-wire smoke detectors on Zone 1. If used, this option limits the number of smoke detectors to a maximum of 10, rather than 16. To enable the “clean me” feature, a time response setting of “3” (1.2 seconds) must be entered in *56 Zone Programming for zone 1.
<b>*177</b>	<b>Device Duration 1, 2</b> 0 = 15 secs    6 = 2-1/2 min    #+12 = 8 min 1 = 30 secs    7 = 3 min        #+13 = 10 min 2 = 45 secs    8 = 4 min        #+14 = 12 min 3 = 60 secs    9 = 5 min        #+15 = 15 min 4 = 90 secs    #+10 = 6 min 5 = 2 min        #+11 = 7 min	These entries set the duration for output action options 5 (Duration 1) and 6 (Duration 2) programmed in *80 Output Function Programming.
<b>*181</b>	<b>50/60 Hz AC Operation</b> 0 = 60 Hz 1 = 50 Hz	Select the type of AC power applied to the control. This option is used for Real-Time Clock synchronization.

## Configurable Zone Type Programming Fields

The system allows you to define up to 4 custom zone types (zone types 90-93), based on the options described. All configurable zone types can be programmed via the downloader. Configurable zone types 90 and 91 can also be programmed from a keypad using data fields \*182-\*185 described below. UL installations: Do not configure zones as fire alarm or UL burglar alarm zones.

**\*182 Configurable Zone Type 90**  
 0-15 = values for each of 10 entries  
 (0-9, # + 10 = 10, # + 11 = 11, # + 12 = 12,  
 # + 13 = 13, # + 14 = 14, # + 15 = 15)

Enter the appropriate value for each entry, 1-10, based on the charts on the next page. To calculate the value for each entry, add the values of the selected options in each of the entry's columns shown in the respective chart (one option per column). For example, to program entry 2 for "alarm response to short," "auto restore on," but not a "vent zone," enter 5 ("1" for alarm short + "4" for auto restore yes + "0" for vent zone no).

**\*183 Zone Type 90 Report Codes**

90 ALARM ID: XXX
TROUBLE ID: XXX

Use existing Contact ID® codes, if appropriate, or define unique codes in CID code range 750-789.

Enter the desired 3-digit Contact ID® report codes for alarms and troubles occurring on zones assigned to this zone type. Press [\*] to accept and continue.

**Important Notice on Report Codes:** To avoid confusion at the central station, it is recommended that existing Contact ID® codes be used with configurable zone types whenever possible. See list in *System Communication* section and/or check with the central station for a complete list of Contact ID® report codes. If none of the codes are suitable, choose a code in the reserved range of 750-789 (reserved for configurable zone type report codes) and make sure to define the code with your central station.

**\*184 Configurable Zone Type 91**  
 see \*182 for entries

See field \*182 for explanation of entries.

**\*185 Zone Type 91 Report Codes**

91 ALARM ID: XXX
TROUBLE ID: XXX

See field \*183 for explanation of entries and read the Important notice on using these codes.

Configurable Zone Type Options	
<b>Auto Restore</b> (entry 2)	Faults on zones set for this option are cleared and restore messages sent upon restoral of faults.
<b>Vent Zone</b> (entry 2)	Zones set for this option are ignored if faulted when arming the system, but are protected if the zone is later restored (e.g., an open window can be ignored when arming, but if the window is later closed, it will be protected; opening the window again causes an alarm.)
<b>Bypass Disarmed</b> (entry 4)	Zones set for this option can be bypassed only while the system is disarmed.
<b>Bypass Armed</b> (entry 4)	Zones set for this option can be bypassed when the system is armed or disarmed.
<b>Dial Delay</b> (entry 6)	Alarms on zones set for this option participate in dial delay central station reporting, if system dial delay enabled in field *50.
<b>Fault Delay</b> (entry 6)	Faults on zones set for this option are delayed by the time set in field *87. Do not use this option if using entry/exit delay for this zone type.
<b>Faults Display</b> (entry 7)	Selects how faults on zones set for this zone type are displayed.
<b>Power Reset/Verification</b> (entry 7)	Selects whether the system resets power (when user enters code + OFF), and whether the system performs alarm verification (see description for zone type 16 in <i>Programming Overview</i> section) when a fault occurs on these zones.
<b>Use Entry Delay</b> (entry 8)	Selects whether to use the system's entry delay times.
<b>Use Exit Delay</b> (entry 8)	Selects whether to use the system's exit delay time.
<b>Interior Type</b> (entry 8)	Zones set for this option are treated same as standard zone type 4 (bypasses when armed STAY, faults displayed).
<b>Alarm Sounds</b> (entry 9)	Selects the type of alarms sound for zones set for this zone type.
<b>Bell Timeout</b> (entry 9)	Alarms on zones set for this option sound for the duration set in fields *32 & *33.
<b>Fire Zone</b> (entry 9)	Zones set for this option respond in the same manner as if programmed for zone type 9. Do not set fire zones to respond as a "fault" in entries 1-6.
<b>Trouble Sounds</b> (entry 10)	Selects the type of trouble sounds for zones set for this zone type (periodic beeps = once every 30 seconds; trouble beeps = rapid beeping).
<b>Chime Enable</b> (entry 10)	Zones set for this option cause a chime when Chime mode is on.

**Configurable Zone Type Charts**

ENTRY 1		ENTRY 2		
Response when system disarmed and zone is:				
Intact EOL <i>RF zone normal</i>	Open <i>RF zone N/A</i>	Shorted <i>RF zn off-normal</i>	Auto Restore	Vent Zone
0 = normal 1 = alarm 2 = trouble 3 = fault	0 = normal 4 = alarm 8 = trouble 12 = fault see note 5	0 = normal 1 = alarm 2 = trouble 3 = fault see note 6	0 = no 4 = yes	0 = no 8 = yes
Entry 1 = EOL + Open		Entry 2 = Short + Auto Restore + Vent Zone		

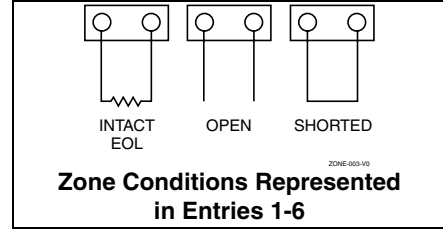

ENTRY 3		ENTRY 4		
Response when armed STAY and zone is:				
Intact EOL <i>RF zone normal</i>	Open <i>RF zone N/A</i>	Shorted <i>RF zn off-normal</i>	Byp. when disarmed	Byp. when armed
0 = normal 1 = alarm 2 = trouble 3 = fault	0 = normal 4 = alarm 8 = trouble 12 = fault see note 5	0 = normal 1 = alarm 2 = trouble 3 = fault see note 6	0 = no 4 = yes	0 = no 8 = yes
Entry 3 = EOL + Open		Entry 4 = Short + Byp. Disarmed + Byp. Armed		

ENTRY 5		ENTRY 6		
Response when armed AWAY and zone is:				
Intact EOL <i>RF zone normal</i>	Open <i>RF zone N/A</i>	Shorted <i>RF zn off-normal</i>	Dial Delay (see field *50)	Fault Delay (see field *87)
0 = normal 1 = alarm 2 = trouble 3 = fault	0 = normal 4 = alarm 8 = trouble 12 = fault see note 5	0 = normal 1 = alarm 2 = trouble 3 = fault see note 6	0 = no 4 = use delay	0 = no 8 = use delay  see note 1
Entry 5 = EOL + Open		Entry 6 = Short + Dial Delay + Fault Delay		

ENTRY 7		ENTRY 8		
Display Faults	Power Reset/ Verification	Use Entry Delay 1/2	Use Exit Delay	Respond as Interior Type
0 = show alarms when armed & disarmed 1 = don't show alarms when armed (show alarms, trbles, faults when disarmed) 3 = never show any alarms, trbles, faults	0 = no 4 = power reset after fault (with code + OFF) 12 = verification (see zone type 16)	0 = no 1 = delay 1 2 = delay 2	0 = no 4 = use exit delay	0 = no 8 = yes  see note 2
Entry 7 = Fault Display + Power Reset/Verification		Entry 8 = Entry Delay 1/Entry Delay 2 + Exit Delay + Interior Zone Type		

ENTRY 9			ENTRY 10	
Alarm Sounds	Use Bell Timeout	Respond as Fire Zone	Trouble Sounds	Chime when Chime Mode On
0 = none 1 = steady keypad 2 = steady bell and keypad 3 = pulsing bell and keypad	0 = no 4 = yes  see fields *32, *33	0 = no 8 = yes  see zone type 09; see note 4	0 = none 1 = periodic beep 2 = trouble beeps	0 = no 4 = yes
Entry 9 = Alarm Sounds + Bell Timeout + Fire Zone			Entry 10 = Trouble Sounds + Chime	

**Configurable Zone Type Notes**

1. Do not use the "fault delay" option with a configurable zone type if it is set for an entry or exit delay, otherwise unpredictable results may occur.
2. To create an interior type zone, select "respond as interior zone type" (entry 8, interior type = yes), and set zone response to "fault" in entries 3-4 to ensure fault displays; do not set as "normal," "alarm," or "trouble."
3. Do not set fire zones to respond as a "fault" (entries 1-6), otherwise faults will not display unless the [\*] key is pressed.
4. 4219/4229 modules must use EOLRs or unpredictable results may occur.
5. RF Zones: The "open" options in entries 1, 3, and 5 are not applicable for RF zones. Use the "intact EOL" option for normal RF zone conditions and "shorted" for off-normal RF zone conditions.
6. a. Zone-Doubling/Double-Balanced: A short on either zone of a zone-doubled pair or on a double-balanced zone causes a tamper condition.  
b. For double-balanced zones, this entry must be "0".  
c. For zone-doubled zones, **both** zones of the doubled pair must be assigned the same response to a short.



## Touch Screen Device (AUI) Enable

FIELD	TITLE and DATA ENTRIES	EXPLANATION
<b>*189</b>	<b>AUI Device 1 and 2 Enable</b> 0 = disabled 1 = partition 1 2 = partition 2 3 = partition 3  AUI 1 address must be set to 1. AUI 2 address must be set to 2.	<b>For Touch Screen style keypads</b> The system supports up to two touch screen style keypads (e.g. Symphony Advanced User Interface (AUI), and FA700KP Touch Screen Keypad). Enter each touch screen (AUI) device's home partition.  NOTE: Use of AUI does not affect the number of standard keypads supported.  <div style="border: 1px solid black; padding: 5px;"> <b>AUI Compatibility Note:</b> To ensure proper AUI device operation, connect only to controls having microprocessor version 3.0 or higher, and use AUI devices with the following rev levels: 6270 series use version 1.0.9 or higher; 8132/8142 (Symphony) series use version 1.1.175 or higher.           </div>

## Keypad Programming Fields

NOTE: Each keypad must be assigned a unique address. Keypads programmed with the same address will give unpredictable results.

FIELD	TITLE and DATA ENTRIES	EXPLANATION
<b>*190</b>	<b>Keypad 2 Device Address 17</b> <b>Entry 1 – Partition Assignment:</b> 0 = keypad disabled 1 = partition 1; 2 = partition 2; 3 = common <b>Entry 2 – Sound Option:</b> 0 = no suppression 1 = suppress arm/disarm and E/E/ beeps 2 = suppress chime beeps only 3 = suppress arm/disarm, E/E/ beeps and chime beeps	<b>Keypad 2</b> Entry 1: Enter the partition in which the keypad is located. Entry 2: Enter the desired sound option for this keypad.  NOTE: Address 16 is reserved for keypad 1, which is automatically set to partition 1 with all sounds enabled.
<b>*191</b>	<b>Keypad 3 Device Address 18</b>	<b>Keypad 3:</b> See field *190 for entries and explanation.
<b>*192</b>	<b>Keypad 4 Device Address 19</b>	<b>Keypad 4:</b> See field *190 for entries and explanation.
<b>*193</b>	<b>Keypad 5 Device Address 20</b>	<b>Keypad 5:</b> See field *190 for entries and explanation.
<b>*194</b>	<b>Keypad 6 Device Address 21</b>	<b>Keypad 6:</b> See field *190 for entries and explanation.
<b>*195</b>	<b>Keypad 7 Device Address 22</b>	<b>Keypad 7:</b> See field *190 for entries and explanation.
<b>*196</b>	<b>Keypad 8 Device Address 23</b>	<b>Keypad 8:</b> See field *190 for entries and explanation.
<b>*197</b>	<b>Exit Time Display Interval</b> 0 = no display 1-5 = seconds between display updates	If enabled, keypads display the exit time remaining after arming the system, with display updates at the interval selected (i.e. if the exit delay is 30 seconds and "2" is selected in this field, the keypad display refreshes every 2 seconds, displaying 30, 28, 26, 24, etc.). An interval greater than "1" may be necessary for some older keypads to allow users time to enter key presses between display updates. <b>FIXED-WORD KEYPAD NOTE:</b> Do not use exit times greater than the 180-second delay option if using 3-digit display keypads, and not greater than the 96-second delay option if using 2-digit display keypads (e.g. FA245RF). Using a longer delay time may cause end-user confusion because 3-digit display keypads cannot display times greater than "199," and 2-digit display keypads cannot display times greater than "99." If longer exit times are required by the installation, it is recommended that exit time display be disabled ("0").
<b>*198</b>	<b>Display Partition Number</b> 0 = no; 1 = yes	If selected, the partition number is displayed in the upper-left corner of the display. This is useful when using the GOTO partition function.
<b>*199</b>	<b>ECP Fail Display</b> 0 = 3-digit display ("1" + device address) 1 = 2-digit fixed-display as "91"	Select "0" if using Alpha keypads and/or 3-digit Fixed-Word Display keypads. ECP faults will display "1" plus the device address (00-30) of device causing the fault (e.g., faults on device 07 display as "107"). Select "1" if using 2-digit Fixed-Word Display keypads (e.g., FA245RF). If selected, ECP faults for all devices will display as "91" on 2-digit displays, and "191" on 3-digit or Alpha keypads. <b>NIGHT-STAY NOTE:</b> Setting this field to "1" disables the control's Night-Stay feature (code + [3] [3]). In addition, the "Canceled Alarm" display is also disabled (field *86).



# Zone Programming

## (\*56 and \*58 Menu Modes)

### About Zone Programming

\*56 Zone Programming is used to program zones, zone types, report codes, enroll 5800 RF Wireless Transmitter serial numbers, and identify the type of loop input device(s). This mode can also be used to enter alpha descriptors for programmed zones; however, we recommend entering descriptors in menu mode \*82 (*Alpha Descriptor Programming* after all zone programming has been completed). For a faster method of zone programming, you can use the \*58 Expert Programming Mode instead of \*56 Zone programming. The \*58 Expert Programming Mode is designed for those who have had previous experience in programming control panels of this type.

**NOTE:** Alpha display prompts are shown in a double-line box.

### \*56 Zone Programming Procedure

Zone Programming involves:

1. Entering the zone number to be programmed;
2. Making appropriate entries at the prompts;
3. Confirming the serial number of wireless transmitter zones.

Start Zone Programming mode by pressing \*56 while in Data Programming mode. The following prompts are displayed:

PROMPT	VALID ENTRIES	EXPLANATION
SET TO CONFIRM? 0 = NO 1 = YES	<b>Set to Confirm</b> 0 = no 1 = yes	If 1 (Yes) is entered, you will be prompted to confirm each transmitter after entering the serial and loop numbers (at the "XMIT TO CONFIRM" prompt later in this procedure). <b>We recommend that you confirm the programming of every transmitter.</b>
Enter Zn Num.                      10 (00 = Quit)	<b>Zone Number</b> 01-08 = wired zones 09-48 = wireless/expander zns 49-64 = RF button zones 91 = addr. device report enable 92 = duress report enable 95, 96, 99 = emergency zones 00 to quit [*] to continue	Enter the zone number that you wish to program. Zone 10 has been entered as an example in the display at left. Enter a report code for zone 91 to enable addressable device reporting. Enter a report code for zone 92 to enable duress reporting. 95, 96, 99 are emergency (panic) key zones.
Zn ZT P RC In: L 10 00 1 10 RF: 1  OR  Zn ZT P RC In: AD 10 00 1 10 AW: 07  OR  Zn ZT P RC HW: RT 10 00 1 10 EL 1	<b>Summary Screen</b> [*] to continue	A summary display appears. "IN: L" appears for wireless zones and indicates input type and loop. "IN: AD" appears for hardwire expansion zones (AW) and indicates the module's address (AD), which is based on the zone number. "HW: RT" appears for hardwire zones and indicates configuration (EOL, NO, NC, zone doubling, double-balanced) and response time selection.



PROMPT	VALID ENTRIES	EXPLANATION
<div style="border: 1px solid black; padding: 5px; width: fit-content;"> 10 INPUT S/N: L  A022-4064 1 </div>	<b>Serial number Entry and Loop Number Entry</b> see explanation [*] to continue	<i>Used only when enrolling wireless transmitters.</i> a. Transmit two open/close sequences. If using a button-type transmitter, press and release the button twice, but wait about 4 seconds before pressing the button the second time. OR b. Manually enter the 7-digit serial number printed on the label of the transmitter. Then press the [*] key – the cursor will move to the “L” position. You can edit the loop number, if necessary. When the loop number is acceptable, press [*]. c. Press key [C] to copy the serial number previously enrolled (used when programming a transmitter with several input loops).
<div style="border: 1px solid black; padding: 5px; width: fit-content;"> 10 INPUT S/N L  A022-4064 ? </div>	<b>Loop Number Change</b> [*] to continue	<b>NOTE:</b> If the [C] key is used to copy the previously enrolled serial number, the cursor will move to the Loop column (L) with the previous serial number displayed, and display a highlighted question mark for the loop number.  Enter the loop number and press [*]. The system will now check for a duplicate serial/loop number combination.
<div style="border: 1px solid black; padding: 5px; width: fit-content;"> 10 INPUT S/N L  A022-4064 1 </div>	<b>Enroll Summary</b> [*] to continue	If the serial/loop number combination is not a duplicate in the system, a display showing the serial number and loop number entry will appear.
<div style="border: 1px solid black; padding: 5px; width: fit-content;"> XMIT TO CONFIRM  PRESS * TO SKIP </div>	<b>Confirmation Option</b> [*] to continue	This prompt will only appear if you answered “Yes” at the first prompt in this section.  The system will enter a confirmation mode so that the operation of the actual programmed input can be confirmed. Activate the loop input or button that corresponds to this zone.
<div style="border: 1px solid black; padding: 5px; width: fit-content;"> Entd A022-4063 1  Rcvd A022-4064 1 </div>	<b>If Serial or Loop Numbers do not match after activating the transmitter</b> [*] to continue	If the serial number transmitted does not match the serial number entered, a display similar to the one shown appears. If the loop number does not match, it will also be displayed. If so, activate the loop input or button on the transmitter once again. If a match is not obtained (i.e., summary display does not appear), press the [#] key twice and then enter (or transmit) the correct serial number.
<div style="border: 1px solid black; padding: 5px; width: fit-content;"> 10 INPUT S/N: L  A000-0000 0 </div>	<b>To Delete a Serial No.</b> enter 0 in loop number field # = undo deletion [*] to continue	To delete an existing serial number, enter <b>0</b> in the loop number field. The serial number will change to <b>0</b> 's. If <b>0</b> was entered in error, simply re-enter the loop number or press [#], and the serial number will return to the display.
<div style="border: 1px solid black; padding: 5px; width: fit-content;"> Zn ZT RC In: L  10 03 10 RF: 1s </div>	<b>Summary Screen</b> [*] to continue	If the serial number transmitted matches the serial number entered, the keypad will beep 3 times and a summary display will appear, showing that zone's programming. Note that an “s” indicates that a transmitter's serial number has been enrolled.  Press [*] to accept the zone information and continue.
<div style="border: 1px solid black; padding: 5px; width: fit-content;"> PROGRAM ALPHA?  0 = NO 1 = YES 0 </div>	<b>Alpha Descriptors</b> 0 = no 1 = yes [*] to continue	If you want to program descriptors for zones now, enter <b>1</b> (Yes) and refer to the <i>Alpha Descriptor Programming</i> section for available descriptors.
<div style="border: 1px solid black; padding: 5px; width: fit-content;"> ENTER ZN NUM.  (00 = QUIT) 11 </div>	<b>Next Zone Number</b> 00 = quit [*] to continue	If <b>0</b> (No) was entered above, the system will return you to the ENTER ZN NUM. prompt for the next zone. When all zones have been programmed, enter <b>00</b> to quit.

## Completing Zone Programming

When you have finished programming all zones, test each zone using the system's TEST mode. **Do not use the Transmitter ID Sniffer Mode for checking wireless transmitting devices**, as it will only check for transmission of one zone on a particular transmitter, NOT the zones assigned to each additional loop.

**NOTE:** Following the successful enrollment of each wireless device, note the device serial number in the appropriate column on the ENROLLED TRANSMITTERS worksheet in the Programming Form; then enter the other information (zone number, zone type, loop number, etc.) relevant to that device.

## \*58 Expert Programming Mode Procedures

This method is designed for use by installers with previous experience in programming First Alert Professional control panels. This mode is also used to program wireless keys using pre-defined templates.

Start Expert Programming mode by pressing \*58 while in Data Programming mode. The following prompts are displayed:

PROMPT	VALID ENTRIES	EXPLANATION
<div style="border: 1px solid black; padding: 5px; width: fit-content;">                     SET TO CONFIRM?                      0 = NO 1 = YES 0                 </div>	<b>Confirm?</b> 0 = no 1 = yes [*] to continue	This display appears upon entry into this mode. The default is 0 (No). If 1 (Yes) is entered, you will be prompted to confirm each transmitter after entering the serial and loop numbers (at the "XMIT TO CONFIRM" prompt later).
<div style="border: 1px solid black; padding: 5px; width: fit-content;">                     Zn ZT P RC HW: RT                      01 09 1 10 EL 1                 </div>	<b>Summary Screen</b> 01-64 = zone number 00 = quit [*] to continue	A summary screen will appear, showing zone 1's currently programmed (or default) values. Enter the zone number being programmed, then press [*], which displays a summary screen for that zone. See next prompt (in this example, zone 10 is being entered). If programming a wireless key, press the [D] key then skip to the Wireless Key Programming Templates section following this section. When [D] is pressed, you can choose from a series of preset templates for easy programming of wireless key zones. When all zones have been programmed, press "00" at this prompt to quit this menu mode.
<div style="border: 1px solid black; padding: 5px; width: fit-content;">                     Zn ZT P RC IN: L                      10 - - - : -                 </div>	OR [D] to go to prompts for wireless key programming templates	
<div style="border: 1px solid black; padding: 5px; width: fit-content;">                     Zn ZT P RC IN: L                      10 00 1 10 RF 1                 </div>	<b>Zone Programming</b> ZT = see Zone Type chart shown in *56 Menu Mode "Zone Type" prompt P = partition 1, 2, 3 (common) RC = 1 (send CID report) 0 (no report) IN = input type L = loop number [*] to continue	A summary screen with the selected zone's current programming appears. Begin programming zone information as follows: <ul style="list-style-type: none"> <li>• Enter Zone Type (ZT), Partition (P), Report Code (RC), and Input Device Type (IN)* sequentially, but not the Loop No. (L).</li> <li>• Use the [A] (Advance) and [B] (Back) keys on the keypad to move the cursor within the screen.</li> <li>• Use the [C] key to copy the previous zone's attributes.</li> </ul> Press [*] to save the programming and continue to the serial number/loop number prompt. If needed, you can press the [#] key to back up without saving. * If HW (hardwired) or AW (Auxiliary) is entered for Input Device Type, the next screen will be similar to the prompt shown, except that HW or AW will be displayed under "IN". If RF, BR, or UR is entered, a prompt for Serial and Loop number will be displayed, as follows.

PROMPT	VALID ENTRIES	EXPLANATION
<div style="border: 1px solid black; padding: 5px; width: fit-content;"> 10 INPUT S/N: L  AXXX-XXX - </div>	<b>Serial number</b> S/N = serial number L = loop number  [*] to continue	Manually enter the serial number (found on the transmitter label), by typing digits in the “X” locations, using the [A] (advance) or [B] (back) keys as required. You can also perform two open and close sequences; for button-type transmitters that means pressing and releasing the button twice.  <b>NOTE:</b> If you want to copy the previous zone’s serial number, press the [C] key.  Press [*] to advance to the loop number, then enter loop number.  Press [*] to accept the existing serial and loop number and continue to the “Confirm” prompt below. If necessary, press [#] to back up and re-enter or edit the serial number.
<div style="border: 1px solid black; padding: 5px; width: fit-content;"> 10 INPUT S/N: L  A000-0000 0 </div>	<b>To Delete a Serial Number</b> [*] to continue	To delete an existing serial number, enter <b>0</b> in the loop number field. The serial number will change to all 0’s as shown. If <b>0</b> was entered in error, simply re-enter the loop number, and the serial number will return to the display.
<div style="border: 1px solid black; padding: 5px; width: fit-content;"> 10 XMIT TO CONFIRM  PRESS * TO SKIP </div>	<b>Confirm</b> [*] to continue	The prompt to confirm appears. This prompt will only appear if the first prompt after entering *58 was answered “Yes.” To confirm, activate the loop input or button that corresponds to this zone. The system checks for duplicate. If a duplicate exists, a long error beep will sound. Press [#] to back up and re-enter the serial and/or loop number.
<div style="border: 1px solid black; padding: 5px; width: fit-content;"> Entd A022-4063  Rcvd A022-4064 </div>	<b>If Serial or Loop Numbers do not match after activating the transmitter</b> [*] to continue	If the serial/loop number combination transmitted does not match the serial and loop number entered, a display similar to the one below will appear. <b>If the loop number does not match, it will also be displayed.</b> If so, activate the transmitter’s loop input or button one or more times. If a match is still not obtained (i.e., summary display does not appear), press the [#] key twice and enter the correct loop input or, if correct, press [#] again and then enter the correct serial number.
<div style="border: 1px solid black; padding: 5px; width: fit-content;"> Zn ZTP RC In L  10 03 1 10 RF: 1s </div> <p>Note that an “s” indicates that a transmitter’s serial number has been enrolled.</p>	<b>Summary Screen</b> [*] to continue	If the serial number transmitted matches the serial number entered, the keypad will beep 3 times and a summary display will appear, showing the programmed information for that zone.  Press [*] to begin programming the next zone. See first “Summary Screen” prompt paragraph on previous page.

## Wireless Key Programming Templates

This procedure programs the wireless keys, **but a key is not active for arming/disarming until it is assigned to a user number** (see *System Operation* section, assigning attributes command).

If the D key was previously pressed (from \*58 Menu mode) to program 5804 and/or 5804BD wireless keys, the following screens appear.

PROMPT	VALID ENTRIES	EXPLANATION
<div style="border: 1px solid black; padding: 5px;">                     TEMPLATE ?                      1-6                      1                 </div>	<b>Template Number</b> 1-3 = 5804 templates 4-6 = 5804BD templates [*] to continue	1. Enter Template number 1-6 (from next page). See the defaults provided for each template in the chart that follows these procedures. 2. Select from templates. Press [*] to display template (1 shown selected). <b>NOTE:</b> If necessary, press [#] to back up and re-enter template number. 3. If you want to return to the *58 Menu mode Summary Screen, press [#].
<div style="border: 1px solid black; padding: 5px;">                     L 01 02 03 04                      T 23 22 21 23                 </div>	<b>Template Display</b> [*] to continue	4. When [*] is pressed, the selected template will be displayed. Top line of display represents loop numbers, bottom line represents zone type assigned for each loop. 5. Press [*] to accept template.
<div style="border: 1px solid black; padding: 5px;">                     PARTITION  <span style="float: right;">1</span> </div>	<b>Partition</b> 1 = partition 1 2 = partition 2 3 = common partition [*] to continue	6. Enter the partition in which the key is to be active. 7. Press [*] to continue.
<div style="border: 1px solid black; padding: 5px;">                     ENTER START ZONE                      00 = QUIT              36                 </div>	<b>Start Zone Number</b> [*] to continue	8. The system will search for the highest available consecutive 4-zone group (the four zones in the case of the 5804 and 5804BD), and display the lowest zone number of the group. If you want to start at a different zone, enter the zone desired, and press [*]. If that zone number is displayed, the system has the required number of consecutive zones available, beginning with the zone you entered. If not, the system will again display a suggested zone that can be used. If the required number of consecutive zones is not available at all, the system will display "00". <b>To quit this mode</b> and return to *58 Menu mode, enter 00 at this prompt. 9. Press [*] to accept.
<div style="border: 1px solid black; padding: 5px;">                     INPUT S/N              L                      AXXX-XXXX            -                 </div>	<b>Serial Number</b> [*] to continue	10. Manually enter the serial number printed on the label for the wireless key or press and release the button to transmit its serial number. 11. Press [*] to accept the serial number. The system will check for duplicate. 12. If necessary, press the [#] key to back up without saving, and re-enter the serial number. Use the [A] key to move forward within the screen, and the [B] key to move backward.
<div style="border: 1px solid black; padding: 5px;">                     XMIT TO CONFIRM                      PRESS * TO SKIP                 </div>	<b>Confirm</b> [*] to continue	13. If "Yes" was entered at the <b>SET TO CONFIRM?</b> prompt previously (see first prompt following entry into the *58 Expert Programming Mode), the display on the left will appear. Confirm serial and loop numbers by activating the wireless key. <b>IMPORTANT:</b> When confirmed, the key is not active for arming/disarming until it is assigned to a user number (using the assigning attributes command, attribute "4"). See <i>System Operation</i> section for procedure.



Entd A022-4063  
Rcvd A022-4064

**Not Confirmed**  
[\*] to continue

If the serial number transmitted does not match the serial number entered, a display similar to the one shown will appear. If the loop number does not match, it will also be displayed.

If so, activate the button on the wireless key once again. If a match is not obtained (i.e., summary display does not appear), press the [#] key and then enter the correct serial number.

If the serial number transmitted matches the serial number entered, the keypad will beep 3 times and will return you to step 8 (Zone Number prompt) to enter the starting zone for the next wireless key. Or you can return to \*58 Menu mode by pressing 00 at the Zone Number prompt.

**NOTE:** Following the successful enrollment of each wireless device, remove **ONE** of the serial number labels from the device and affix it in the appropriate column on the ENROLLED TRANSMITTERS worksheet of the Programming Form; then enter the other information (zone number, zone type, loop number, etc.) relevant to that device.

### Wireless Key Predefined Default Templates

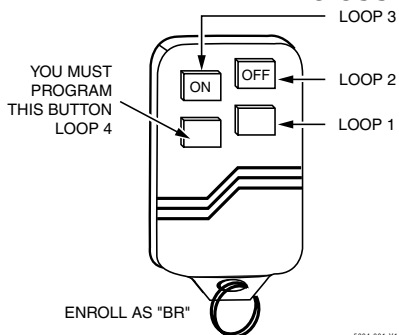

**Note:**  
These transmitters are not intended for use in UL installations.

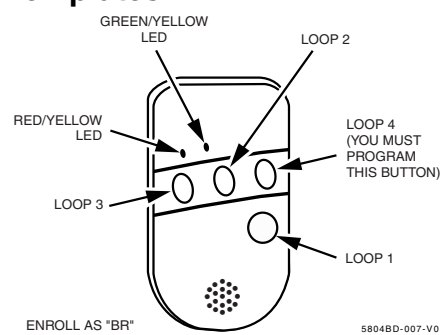

**5804BD 2-Way Wireless Key Transmitter**

#### 5804 Wireless Key Transmitter

For 5804				For 5804BD			
TEMPLATE 1	Loop	Function	Zone Type	TEMPLATE 4	Loop	Function	Zone Type
	1	No Response	23		1	No Response	23
	2	Disarm	22		2	No Response	23
	3	Arm Away	21		3	Arm Away	21
	4	No Response	23		4	Disarm	22
TEMPLATE 2	Loop	Function	Zone Type	TEMPLATE 5	Loop	Function	Zone Type
	1	No Response	23		1	No Response	23
	2	Disarm	22		2	Arm Stay	20
	3	Arm Away	21		3	Arm Away	21
	4	Arm Stay	20		4	Disarm	22
TEMPLATE 3	Loop	Function	Zone Type	TEMPLATE 6	Loop	Function	Zone Type
	1	24-hour audible	7		1	24-hour audible	7
	2	Disarm	22		2	Arm Stay	20
	3	Arm Away	21		3	Arm Away	21
	4	Arm Stay	20		4	Disarm	22



# Output Device Programming

## (\*79/\*80 Menu Mode)

### About Output Device Programming

**Output Devices:** The system supports up to 16 relays and/or Powerline Carrier devices (X-10 devices) plus 2 built-in trigger outputs in any combination. These 18 “outputs” are assigned to system-wide output numbers (01-18). Use \*79 Menu Mode to assign output numbers and map them to device addresses.

**Output Functions:** The system also provides installer-defined output functions, which can be assigned to any of the physical outputs. Therefore, the action of any one of the outputs can be based on as many of these functions as desired. This lets a single relay or X-10 device perform many functions. The controls support up to 48 output functions. Use \*80 Menu Mode to define output functions.

---

Relays and output devices are not recommended for life safety applications.

---

**NOTE:** When navigating the \*79 and \*80 menus: The [\*] key is used to accept an entry and advance to the next prompt. The [#] key is used to revert back to the last question to check or change an entry. Press [\*] to go forward again.

Output Device programming involves:

1. Use \*79 Menu Mode to assign module and output numbers and map them to device addresses.
 

**NOTE:** You must map output devices using \*79 Menu Mode **before** you can use \*80 menu Mode).
2. Use \*80 Menu Mode to create output definitions, which control the output devices.

### \*79 Menu Mode: Output Device Mapping

Use this menu to assign Relay Module device addresses and specific relay numbers, and Powerline Carrier unit numbers. The system is based on predefined module addresses for 4204 and 4229 modules. Refer to the table shown at the “Module Address” prompt on the next page and set the modules’ addresses (via module DIP switches) accordingly.

The following table shows how these outputs are identified.

#### Output Identification

This output...	is identified by...
Relays:	the Relay Module’s device address and the relay position on that module (i.e. the physical relay number, 1-4, on that module).
X-10 Device	a house ID (entered in data field *27) and the unit number of the device.
Built-in Outputs	the output number assigned, 17 for Trigger 1 and/or 18 for Trigger 2.

Start Output Device Mapping by pressing \*79 while in Data Programming Mode. The following prompts are displayed:

**\*79 Menu Mode**

PROMPT	VALID ENTRIES	EXPLANATION																				
<div style="border: 1px solid black; padding: 5px; width: fit-content;">                     ENTER OUTPUT NO.                      00 = QUIT                      xx                 </div>	<b>Device Output Number</b> 01-16, 17, 18 [*] to continue	This is the logical (or reference) relay number as used in the system. Relays and X-10 devices are numbered 01-16; the on-board triggers are numbered 17 and 18 and can be programmed for inverted output. Use the worksheet on the Programming Form (printed separately) to organize device numbers.																				
<div style="border: 1px solid black; padding: 5px; width: fit-content;">                     17 OUT NORM LOW                      0 = NO 1 = YES                      0                 </div>	<b>Output Normally Low</b> 0 = no (standard default) 1 = yes [*] to continue	This prompt appears only for Triggers 17 and 18. Selecting 0 (no) sets the output level normally high. Selecting 1 (yes) sets the output normally low. Output Trigger 17 can be used for resetting 4-wire smoke detectors by connecting it to the negative power terminal of the smoke detector, selecting 1 at this prompt, and setting as zone type 54, fire zone reset, in *80 Menu mode. After entry, display returns to Output Number prompt. Use *80 Menu mode to program the function of the trigger.																				
<div style="border: 1px solid black; padding: 5px; width: fit-content;">                     XX OUTPUT TYPE                      DELETE                                      0                 </div>	<b>Output Type</b> 0 = delete 1 = relay on 4204/4229 module 2 = Powerline Carrier device [*] to continue	Select whether this is a relay or a Powerline Carrier (X-10) device. If X-10 is selected, go to "A" prompt. If relay is selected, skip to "B" prompt.																				
<p>"A"</p> <div style="border: 1px solid black; padding: 5px; width: fit-content;">                     XX UNIT No.  <span style="float: right;">yy</span> </div>	<b>Unit Number</b> 01-16 = predefined address [*] to continue	If X-10 is selected, a prompt for the unit number appears. Enter the unit code (set at the device) and press [*]. The system returns to the Output Number prompt.																				
<p>"B"</p> <div style="border: 1px solid black; padding: 5px; width: fit-content;">                     XX MODULE ADDR                      07-15                                      yy                 </div>	<b>Module Address</b> 07-15 = predefined address [*] to continue	If relay is selected, this prompt appears. Enter the predefined address for this module as listed below. Make sure the module's DIP switches are set to the selected address.																				
<p><b>Module Addresses</b></p> <table border="1" style="width: 100%; border-collapse: collapse;"> <thead> <tr> <th style="width: 15%;">Address</th> <th style="width: 85%;">Module</th> </tr> </thead> <tbody> <tr><td>07</td><td>1st 4229 (with zones 09-16)</td></tr> <tr><td>08</td><td>2nd 4229 (with zones 17-24)</td></tr> <tr><td>09</td><td>3rd 4229 (with zones 25-32)</td></tr> <tr><td>10</td><td>4th 4229 (with zones 33-40)</td></tr> <tr><td>11</td><td>5th 4229 (with zones 41-48)</td></tr> <tr><td>12</td><td>1st 4204</td></tr> <tr><td>13</td><td>2nd 4204</td></tr> <tr><td>14</td><td>3rd 4204</td></tr> <tr><td>15</td><td>4th 4204</td></tr> </tbody> </table>			Address	Module	07	1st 4229 (with zones 09-16)	08	2nd 4229 (with zones 17-24)	09	3rd 4229 (with zones 25-32)	10	4th 4229 (with zones 33-40)	11	5th 4229 (with zones 41-48)	12	1st 4204	13	2nd 4204	14	3rd 4204	15	4th 4204
Address	Module																					
07	1st 4229 (with zones 09-16)																					
08	2nd 4229 (with zones 17-24)																					
09	3rd 4229 (with zones 25-32)																					
10	4th 4229 (with zones 33-40)																					
11	5th 4229 (with zones 41-48)																					
12	1st 4204																					
13	2nd 4204																					
14	3rd 4204																					
15	4th 4204																					
<div style="border: 1px solid black; padding: 5px; width: fit-content;">                     XX REL POSITION                      1-4    zz                 </div>	<b>Relay Position</b> 1-4 = relay position [*] to continue	This is the actual (or physical) relay number with respect to the Relay Module upon which it is located. For 4204 modules, relay numbers are 1-4. For 4229 modules, relay numbers are 1-2. The system returns to the Output Number prompt for programming the next device.																				

## \*80 Menu Mode: Defining Output Functions

Use this mode to program output function definitions (up to 48 functions) that provide automated control of any of the output devices, based on events occurring on individual zones or zones with certain zone types. Each output definition is identified by an output function number, and includes the following components:

### Output Definition Components

Component	Description
Output Function No.	A reference number that defines an output's characteristics.
Activated By	Determines whether the initiating event occurs on a zone, a zone list, or a zone type.
Event	Event that triggers the output action. Can be an event occurring on a specific zone number or a zone list, or a specific zone type.
Partition	If the output is activated by zone type, this defines the partition in which the programmed event is to cause the device action.
Output Action	Defines the action of the relay/X-10 device when the defined event occurs. Can close for 2 seconds, stay closed until reset, continuously pulse (1-second close-open-close-open, etc.), toggle the device state, or activate for a defined duration (set in data field *177).
Output No.	Assigns this function to a specific output number (defined in *79 Menu Mode). This is the output number that will perform this function upon the triggering event. Note that each defined function is associated with only one output number. This means that if more than one output device needs to perform this particular function, you need to define another output function number with the same attributes, but assign the appropriate output number. (i.e. output devices can be assigned more than one function number, but each function number can only be assigned a single output number.

**For example**, if you want to pulse a strobe light upon fire alarms on zone 4 using a relay mapped to output number 2 (as programmed in \*79 Menu Mode), program the following in \*80 Menu Mode:

**Prompt**                      **Entry**  
 Output Funct. # = 01 (assuming this is the first output function)  
 Activated By:    = 3 (zone number)  
 Enter Zn No.    = 04 (requires 2-digit zone numbers)  
 Output Action   = 3 (continuous pulse)  
 Output Number = 02 (device mapped in \*79 Menu Mode)

Start Output Definition mode by pressing \*80 while in Data Programming mode. The following prompts are displayed:

### \*80 Menu Mode

PROMPT	VALID ENTRIES	EXPLANATION
<div style="border: 1px solid black; padding: 5px; display: inline-block;">           Output Funct. #            (00 = Quit)      01         </div>	<b>Output Function No.</b> 01-48 = output function number [*] to continue	Enter the output function number to be defined (or 00 to exit).
<div style="border: 1px solid black; padding: 5px; display: inline-block;">           01 A E P Trig            ?00 0 0 -ZL=00         </div>	<b>Summary Screen</b> [*] to continue	This screen displays a summary of the current output programming (for this example, Zone List has been selected-this is the default screen).  <b>A</b> = Output Action; <b>E</b> = Triggering event; <b>P</b> = Partition; <b>Trig</b> = Trigger type  <b>NOTE:</b> A question mark in the summary screen indicates that the device number shown has not been mapped. Use *79 Menu mode to map the device.

01 Activated By:  
Zone List

**Activated By**  
0 = delete  
1 = zone list  
2 = zone type  
3 = zone number  
[\*] to continue

Select where the initiating event for this output definition is to occur as follows:

0 = delete (deletes the output function and any previous programming;-see prompt below)

1 = zone list (go to "A" prompt)

2 = zone type (go to "B" prompt)

3 = zone number (go to "C" prompt)

If you enter "0," the following prompt appears:

Delete?  
0 = NO, 1 = YES

Press 1 to delete this output definition.

"A"

01 Zn List  
1

**Zone List**  
01-08 = zone list  
[\*] to continue

If zone list was selected, this screen appears. Otherwise skip to the next row.

Enter the desired zone list number associated with this output number.

**NOTE:** Do not use pager zone lists 09-12 in output definitions. Press [\*] to continue.

Enter the zone list event that will activate this output.

Enter Event  
Alarm 1

0 = restore; 1 = alarm;  
2 = fault; 3 = trouble

**NOTE:** For alarm, fault, and trouble, an event on ANY zone in the list activates the output, but ALL zones in the list must be restored before the output is restored.

Press [\*] to continue and skip to the "Output Action" prompt.

"B"

01 Enter Zn type  
Perimeter 03

**Zone Type**  
see list at right

If zone type was selected, this screen appears. Otherwise skip to the next row. Enter the desired zone type associated with this output number. See below for a list of available zone types.

**CHOICES FOR ZONE TYPES:**

- |                        |                              |                             |
|------------------------|------------------------------|-----------------------------|
| 00 = Not Used          | 05 = Trouble Day/Alarm Night | 14 = Carbon Monoxide        |
| 01 = Ent/Exit #1       | 06 = 24 Hr Silent            | 15 = 24 Hr Personal/Medical |
| 02 = Ent/Exit #2       | 07 = 24 Hr Audible           | 16 = Fire w/verification    |
| 03 = Perimeter         | 08 = 24 Hr Aux               | 23 = No Alarm Response      |
| 04 = Interior Follower | 09 = Fire                    | 24 = Silent Burglary        |
|                        | 10 = Interior w/Delay        | 77 = Keyswitch zone         |
|                        | 12 = Monitor Zone            | 81 = AAV Monitor Zone       |
|                        |                              | 90-91 = Configurable        |

**CHOICES FOR SYSTEM OPERATION:**

- |                          |                           |                          |
|--------------------------|---------------------------|--------------------------|
| 20 = Arming-Stay (RF)    | 36 = **At Bell Timeout*** | 52 = Kissoff             |
| 21 = Arming-Away (RF)    | 38 = Chime                | 54 = Fire Zone Reset     |
| 22 = Disarming (RF)      | 39 = Any Fire Alarm       | 58 = Duress              |
| 31 = End of Exit Time    | 40 = Bypassing            | 60 = AAV                 |
| 32 = Start of Entry Time | 41 = **AC Power Failure   | 66 = Function Key†       |
| 33 = Any Burglary Alarm  | 42 = **System Battery Low | 67 = Bell Fail           |
|                          | 43 = Comm. Failure        | 68 = Telco line cut      |
|                          |                           | 76 = Arming-Maximum (RF) |
|                          |                           | 78 = Keyswitch red LED   |
|                          |                           | 79 = Keyswitch green LED |

\*\* Use 0 (Any) for Partition No. (P) entry.

\*\*\* Or at Disarming, whichever occurs earlier.

† Use \*57 Menu Mode to assign the function key (function "07").

**Note:** In normal operation mode:

Code + # + 7 + NN Key Entry **starts** Device NN.

Code + # + 8 + NN Key Entry **stops** Device NN.

Enter the partition in which this zone type will occur.

01 Partition  
Any partition 0

0 = any partition; 1 = partition 1;  
2 = partition 2; 3 = common

Press [\*] to continue and skip to the "Output Action" prompt.

“C”

01 Enter Zn No.
12

### Zone Number

If zone number was selected, this screen appears.  
Enter the desired zone number associated with this output number.  
Press [\*] to continue.  
Enter the zone event that will activate this output.

01 Enter Event
Restore 0

0 = restore; 1 = alarm/fault/trouble

Press [\*] to continue to the “Output Action” prompt

01 Output Action
Close for 2 sec 1

### Output Action

0-6 = see list at right

Enter the desired device action as listed below. Press the [\*] key to continue.

0 = off  
1 = Close for 2 seconds  
2 = Stay Closed  
3 = Pulse 1 sec ON, 1 sec OFF  
4 = Change Device State  
5 = Duration 1 (see data field \*177)  
6 = Duration 2 (see data field \*177)

Enter Output No.
R02 02

### Output Number

01-16 = output no.  
17-18 = on-board triggers

Enter the device output number (programmed in \*79 Menu Mode) you want associated with this output.  
Press [\*] to continue.

02 A E P TRIG
R02 1 1 3 ZL=00

### Summary Screen

A summary screen appears showing the programmed settings.  
Press [\*] to continue.





# SECTION 7

## Zone Lists

### (\*81 Menu Mode)

### About Zone Lists

Zone lists let you group individual zones for use with certain system actions. The following table shows the available zone lists and their purposes:

List No.	Used for...
1, 2	general purpose
3	chime-by-zone
4	cross zones
5	night stay zones (night-stay feature is disabled if field *199 is set to "1")
6, 7, 8	general purpose
9	zones that activate Pager 1
10	zones that activate Pager 2
11	zones that activate Pager 3
12	zones that activate Pager 4

### Zone List Programming

Zone List programming involves:

1. Selecting an appropriate zone list number;
2. Adding the desired zone numbers to be included in that list.

Start Zone List Program Mode by pressing \*81 while in Data Programming mode. The following prompts are displayed:

#### \*81 Menu Mode

PROMPT	VALID ENTRIES	EXPLANATION
Zone List No. (00 = Quit)      01	<b>Zone List Number</b> 01-12 = zone list number [*] to continue	Enter the Zone List Number to program (or 00 to end these entries). Press [*] to advance.  In the following displays, zone list 01 has been selected for programming.
01 Enter Zn Num. (00 = Quit)      00	<b>Zone Number</b> 01-64 = zone numbers followed by [*] to accept each zone 00 to continue	Enter each zone number to add to the zone list, followed by pressing [*] (example, 01*, 02*, 03*). After all zones are entered, press 00 to continue.  <b>IMPORTANT:</b> Do not include fire zones in zone lists that are used to STOP device actions.
01 Del Zn List? 0 = No 1 = Yes    0	<b>Deleting Zone Lists</b> 0 = don't delete list 1 = delete this zone list [*] to continue	To delete the zone list, enter 1. All zones in the zone list will be deleted automatically and the system returns to the Zone List No. prompt.  To save the zone list, enter 0.
01 Delete Zone? 0 = No 1 = Yes    0	<b>Deleting a Zone</b> 0 = don't delete zones 1 = go to next prompt to delete zones [*] to continue	To save the entire zone list, enter 0 and the system returns to the Zone List No. prompt.  To delete a zone or zones in a zone list enter 1 to continue.
01 Zn to Delete? (00 = Quit)      00	<b>Delete the Zone</b> 01-64 = zones to be deleted from list followed by [*] to accept each zone 00 to continue	Enter each zone to be deleted from the list, followed by [*]. After all zones to be deleted are entered, enter 00 to return to the Zone List No. prompt so that another list can be programmed, if desired.

**Notes:**

- Any list may include any or all of the system's zone numbers.
- A zone list can be assigned to more than one output relay.
- When creating zone list 4 for cross zoning, include only zones assigned to zone types 3, 4, or 5. Do not include zones that have delays (entry/exit zones, interior w/delay) or 24-hour zones, as these zone types may produce unpredictable operation and may not function as intended.

# Function Key Programming

## (\*57 Menu Mode)

### About Function Key Programming

The system provides the ability to program each of the four keypad function keys to perform one of 12 system operations. The end user can then activate the function by simply pressing and holding the programmed key for 2 seconds. Typical functions (listed below) include single-button arming, turning lights on/off, or single-button paging.

### Programming Function Keys

Function key programming involves:

1. Assigning the function key number and partition;
2. Selecting the desired function for that key.

Start Function Key Programming mode by pressing \*57 while in Data Programming mode. The following prompts are displayed:

PROMPT	VALID ENTRIES	EXPLANATION
<div style="border: 1px solid black; padding: 5px; width: fit-content;">                     Press Key to Pgm                      0 = Quit            0                 </div>	<p><b>Function Key</b>                      Press the desired function key, A-D.</p> <p>[*] to continue</p>	<p>Press the desired function key (A-D) you want to program.  <b>NOTE:</b> A key programmed as a function key is no longer available to be used as an end-user macro key or panic key.</p> <div style="display: flex; justify-content: space-around; align-items: flex-start;"> <div style="text-align: center;"> <p><b>A</b> → <input type="text"/></p> <p><b>B</b> → <input type="text"/></p> <p><b>C</b> → <input type="text"/></p> <p><b>D</b> → <input type="text"/></p> </div> <div style="text-align: center;"> <p><b>1</b> OFF</p> <p><b>4</b> MAX</p> <p><b>7</b> INSTANT</p> <p><b>*</b> READY</p> </div> <div style="text-align: center;"> <p><b>2</b> AWAY</p> <p><b>5</b> TEST</p> <p><b>8</b> CODE</p> <p><b>0</b></p> </div> <div style="text-align: center;"> <p><b>3</b> STAY</p> <p><b>6</b> BYPASS</p> <p><b>9</b> CHECK</p> <p><b>#</b></p> </div> </div> <p style="font-size: small; text-align: right; margin-top: 10px;">keypad_keys-00-001-1/0</p>
<div style="border: 1px solid black; padding: 5px; width: fit-content;">                     Partition  <span style="float: right;">1</span> </div>	<p><b>Partition Number</b>                      1 = partition 1                      2 = partition 2                      3 = common partition</p> <p>[*] to continue</p>	<p>Enter the partition in which the function key is active.</p>
<div style="border: 1px solid black; padding: 5px; width: fit-content;">                     Key "A" Func                      Zone 95            00                 </div>	<p><b>Define Key Function</b>                      00-12 = see list to right</p> <p>[*] to continue                      Returns to key number prompt with the next function key letter displayed.</p> <p>† System defaults to these function key settings.                      †† If night-stay zones are listed in zone list 5.</p>	<p>Enter the desired function for this key, 00 to 12, from the options listed. (00 selected for example display shown at left)</p> <p>00<sup>†</sup> = For the Function key selected, the function will be as follows:                      If A selected = Zone 95 (emergency key, same as [1] [*] pair)                      If B selected = Zone 99 (emergency key, same as [*] [#] pair)                      If C selected = Zone 96 (emergency key, same as [3] [#] pair)                      If D selected = Single-button paging</p> <p>01 = Single-button paging (sends a 999-9999 message to pager)                      02 = Display time                      03 = Arm AWAY (reports as User 00 if closing reports are enabled)                      04 = Arm STAY (reports as User 00 if closing reports are enabled)                      05 = Arm NIGHT-STAY (reports as User 00 if closing reports enabled)                      06 = Step Arming (arms STAY, then NIGHT-STAY††, then AWAY)                      07 = Output Device Control (for device programmed as system operation type 66–function key in *80 Menu Mode)                      08 = Communication Test (sends Contact ID code 601)                      09 = Macro Key 1 (define macro by user code + [#] [6] [6] command)                      10 = Macro Key 2 (define macro by user code + [#] [6] [6] command)                      11 = Macro Key 3 (define macro by user code + [#] [6] [6] command)                      12 = Macro Key 4 (define macro by user code + [#] [6] [6] command)</p>



# Alpha Descriptor Programming

## (\*82 Menu Mode)

### About Descriptor Programming

The system lets you assign zone descriptors for protection zones, keypad panics, and RF receiver supervision faults. Each description can be composed of a combination of words (up to 3) selected from a vocabulary of 196 words stored in memory (see a following page). In addition, up to 10 installer-defined words can be added to those already in memory, plus 3 additional words can be assigned as partition descriptors. Thus, when an alarm or trouble occurs in a zone, an appropriate description for that zone's location can be displayed at the keypad. Zone descriptors are recommended for systems using Alpha display keypads, and are necessary if an FA4285 or FA4286VIP Phone Module is used.

**NOTE:** You can enter zone descriptors when the zone is being defined in \*56 Menu mode, but we recommend you do it using \*82 Menu mode.

---

If using a VIP Phone Module, select from those words in the Alpha Vocabulary List shown in **boldface type**. The phone module will not provide annunciation of the other words.

If a Phone Module is added to an existing system, the Alpha descriptors presently in the system should be reprogrammed, selecting from those words shown in **boldface type** in the Alpha Vocabulary List. The phone module will not provide annunciation of any other words.

---

### Programming Zone Descriptors (Menu Mode \*82)

Descriptor programming involves:

1. Entering index numbers for up to three words from the vocabulary list for each descriptor;
2. Entering up to ten 10-digit custom words, if desired, which can then be used in descriptors.

When defining descriptors:

- Pressing the [6] key accepts the entered index number and moves the cursor to the next position for a descriptor.
- Pressing the [8] key saves the entered descriptor and moves to the next descriptor.

Start Zone Descriptor Programming mode by pressing \*82 while in Data Programming mode. The following prompts are displayed:

PROMPT	VALID ENTRIES	EXPLANATION
<div style="border: 1px solid black; padding: 5px; width: fit-content;">                     Program Alpha ?                      0=No, 1=Yes 00                 </div>	<b>Program Alpha</b> 0 = no 1 = yes [*] to continue	The "Program Alpha ?" prompt will appear. Press 1 to continue.
<div style="border: 1px solid black; padding: 5px; width: fit-content;">                     Custom Words ?                      0=No, 1=Yes 00                 </div>	<b>Custom Words</b> 0 = no 1 = yes [*] to continue	The "Custom Words" prompt will appear. Press 0 to program standard alpha descriptors from the fixed vocabulary. The system will then automatically display the descriptor for zone 1. Press 1 to define custom words (described later in "Adding Custom Words" section).
<div style="border: 1px solid black; padding: 5px; width: fit-content;">                     * ZN 01                 </div>	<b>Summary Screen</b> [*] to continue	Note that this is a "Summary mode," and that no entries can be made. Entries can be made only when the display contains a flashing cursor, which signifies the "Entry mode." Press [*] to continue.

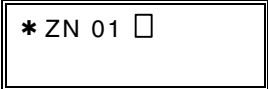
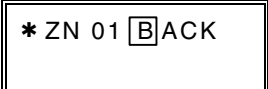
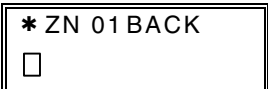
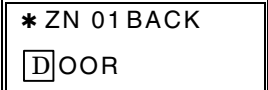
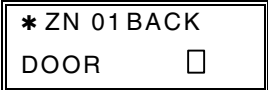
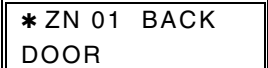
	<b>Flashing Cursor</b>	<p>To delete or change the default descriptor for zone 1, press [*] plus the same zone number (01). This will clear that descriptor and allow changes to be made at the flashing cursor.</p> <p><b>NOTE:</b> If you do not wish to change the existing descriptor for zone 1, enter [*] plus the next zone number for which you wish to enter (or check) a descriptor. A summary display for that zone will appear. You must then press [*] plus the same zone number again to gain access to the entry mode (flashing cursor) for that zone.</p>
	<b>First 3-Digit Index No.</b> see index for entries	<p>Press [#] plus the 3-digit number for the first word from the Alpha Vocabulary List. Example: The descriptor that we wish to enter for zone 1 is BACK DOOR. From the list, BACK = 013. Therefore, you would enter #013.</p> <p>Note: If you accidentally enter the wrong word, simply press [#] plus the correct 3-digit number for the word you want.</p>
	<b>Accept First Word</b> 6 = save word and go to next word in this descriptor 8 = save word and end descriptor- go to next zone	<p>Press [6] to accept the selected word and continue to the next word.</p> <p>NOTE: If this is the only word you are using for the descriptor, press [8] instead of [6] to save that word in memory.</p>
	<b>Second 3-Digit Index No.</b> see index for entries	<p>Enter the 3-digit number for the next word. In our example, the word is DOOR, whose number is "057."</p> <p>Enter # 0 5 7.</p>
	<b>Accept Second Word</b> 6 = save word and go to last word in this descriptor 8 = save word and end descriptor- go to next zone	<p>Press [6] to accept the selected word.</p> <p>NOTE: If these are the only words you are using for the descriptor, press [8] instead of [6] to save them in memory.</p> <p>The two words in our example have now been entered. Note, however, that up to three words may be entered (provided the number of characters will fit on the screen).</p> <p>Press [8] to save all words in memory.</p>
	<b>Summary Screen</b>	<p>The flashing cursor will disappear, indicating that the word(s) are stored in memory for that zone, as shown in the summary display at the left.</p> <p>To enter a descriptor for the next zone, press [*] plus the desired zone number (e.g., *02). The summary display will appear. Now repeat the previous steps to enter the descriptor for the next zone.</p> <p>To exit the Alpha descriptor mode, press * + 0 + 0 at the summary display.</p>

---

## Adding Custom Words (will not be announced by FA4285/FA4286 Phone Module)

You can add up to 10 installer-defined words to the built-in vocabulary, which can then be used when programming zone descriptors. Each of the 10 words can actually consist of a word string of one or more words, but no more than *ten* characters can be used for each word or word string.

When adding custom words, the keypad keys perform the following functions:

- [4] Moves cursor one space to the left.
- [6] Moves cursor one space to the right.
- [8] Saves the new word in the system's memory.

1. Select Custom Word mode (enter 1) when the prompt “CUSTOM WORD ?” is displayed.
2. Enter the number (01–10†) of the custom word or word string to be created, corresponding to index numbers 245 - 254 respectively (for example, if you are creating the first custom word or word-string, enter 01, for the second, enter 02, etc.). A cursor will now appear at the beginning of the second line.

† or 11, 12, 13 for partition 1, partition 2 and common partition descriptors respectively. See Assigning Partition Descriptors paragraph below.

**NOTE:** Custom words 8, 9, and 10 are “reminder words” that can be programmed to display using Scheduling Mode.

3. Refer to the Character List of letters, numbers, and symbols on a following page.  
Press [#], followed by the two-digit entry for the first letter you would like to display (e.g., # 6 5 for “A”).  
The cursor will then move to the right, in position for the next character.
4. Repeat Step 3 to create the desired word(s). Note that the “4” key can be used to move the cursor to the left, if necessary. Remember, no word or word-string can exceed 10 characters.
5. Press the [8] key to save the custom word(s) and return to the “CUSTOM WORD ?” display.  
Repeat Steps 2–5 for other custom words to be entered. To change a custom word, just overwrite it. If no more are to be entered now, press [0] to return to the Descriptor entry. The custom word(s) will be automatically added to the built-in vocabulary.

### Assigning Partition/Custom Message Descriptors

You can assign a partition descriptor (up to 16 characters) for each partition plus the common lobby.

Use the same procedure as for adding custom words (described above), but use the following word numbers in step 2:

- 11 = partition 1 \_\_\_\_\_
- 12 = partition 2 \_\_\_\_\_
- 13 = common lobby \_\_\_\_\_

Use the SPACE character (#32) to delete existing characters.

Once a custom word is entered in any of these word locations (11-13), the system displays the appropriate partition’s word instead of the normal “DISARMED READY TO ARM” message.

## ALPHA VOCABULARY LIST (For Entering Zone Descriptors)

000 (Word Space)	<b>E</b>	115 LOCK	169 SHOCK
	• <b>065 EAST</b>	116 LOOP	• <b>170 SHOP</b>
• <b>001 AIR</b>	066 ELECTRIC	117 LOW	• <b>171 SHORT</b>
• <b>002 ALARM</b>	067 EMERGENCY	• <b>118 LOWER</b>	• <b>173 SIDE</b>
004 ALLEY	068 ENTRY		174 SKYLIGHT
005 AMBUSH	• <b>069 EQUIPMENT</b>	<b>M</b>	175 SLIDING
• <b>006 AREA</b>	• <b>071 EXIT</b>	• <b>119 MACHINE</b>	• <b>176 SMOKE</b>
• <b>007 APARTMENT</b>	072 EXTERIOR	121 MAIDS	• <b>178 SONS</b>
• <b>009 ATTIC</b>		122 MAIN	• <b>179 SOUTH</b>
010 AUDIO	• <b>073 FACTORY</b>	• <b>123 MASTER</b>	180 SPRINKLER
	075 FAMILY	• <b>125 MEDICAL</b>	• <b>182 STATION</b>
<b>B</b>	• <b>076 FATHERS</b>	126 MEDICINE	184 STORE
• <b>012 BABY</b>	• <b>077 FENCE</b>	128 MONEY	• <b>185 STORAGE</b>
• <b>013 BACK</b>	• <b>079 FIRE</b>	129 MONITOR	186 STORY
• <b>014 BAR</b>	• <b>080 FLOOR</b>	• <b>130 MOTHERS</b>	190 SUPERVISED
• <b>016 BASEMENT</b>	081 FLOW	• <b>131 MOTION</b>	191 SUPERVISION
• <b>017 BATHROOM</b>	082 FOIL	132 MOTOR	192 SWIMMING
• <b>018 BED</b>	• <b>083 FOYER</b>	<b>N</b>	193 SWITCH
• <b>019 BEDROOM</b>	084 FREEZER	• <b>134 NORTH</b>	<b>T</b>
020 BELL	• <b>085 FRONT</b>	135 NURSERY	194 TAMPER
• <b>021 BLOWER</b>			196 TELCO
• <b>022 BOILER</b>	<b>G</b>	<b>O</b>	197 TELEPHONE
023 BOTTOM	• <b>089 GARAGE</b>	• <b>136 OFFICE</b>	• <b>199 TEMPERATURE</b>
025 BREAK	• <b>090 GAS</b>	• <b>138 OPEN</b>	200 THERMOSTAT
• <b>026 BUILDING</b>	091 GATE	• <b>139 OPENING</b>	• <b>201 TOOL</b>
	• <b>092 GLASS</b>	• <b>140 OUTSIDE</b>	202 TRANSMITTER
	093 GUEST	142 OVERHEAD	
	094 GUN		
028 CABINET		<b>P</b>	<b>U</b>
• 029 CALL		143 PAINTING	• <b>205 UP</b>
030 CAMERA		• <b>144 PANIC</b>	• <b>206 UPPER</b>
031 CAR	• <b>095 HALL</b>	145 PASSIVE	• <b>207 UPSTAIRS</b>
033 CASH	• <b>096 HEAT</b>	• <b>146 PATIO</b>	• <b>208 UTILITY</b>
034 CCTV	098 HOLDUP	147 PERIMETER	
035 CEILING	099 HOUSE	• <b>148 PHONE</b>	<b>V</b>
036 CELLAR		150 POINT	209 VALVE
• <b>037 CENTRAL</b>	<b>I</b>	151 POLICE	210 VAULT
038 CIRCUIT	100 INFRARED	• <b>152 POOL</b>	212 VOLTAGE
• <b>040 CLOSED</b>	• <b>101 INSIDE</b>	• <b>153 POWER</b>	
• <b>046 COMPUTER</b>	102 INTERIOR		<b>W</b>
047 CONTACT	103 INTRUSION		213 WALL
			214 WAREHOUSE
• <b>048 DAUGHTERS</b>	<b>J</b>	155 RADIO	• <b>216 WEST</b>
049 DELAYED	104 JEWELRY	• <b>156 REAR</b>	• <b>217 WINDOW</b>
• <b>050 DEN</b>		157 RECREATION	• <b>219 WING</b>
051 DESK	<b>K</b>	159 REFRIGERATION	220 WIRELESS
• <b>052 DETECTOR</b>	• <b>105 KITCHEN</b>	160 RF	
• <b>053 DINING</b>		• <b>161 RIGHT</b>	<b>X</b>
054 DISCRIMINATOR	<b>L</b>	• <b>162 ROOM</b>	222 XMITTER
055 DISPLAY	• <b>106 LAUNDRY</b>	163 ROOF	
• <b>057 DOOR</b>	• <b>107 LEFT</b>		<b>Y</b>
• <b>059 DOWN</b>	108 LEVEL	164 SAFE	223 YARD
• <b>060 DOWNSTAIRS</b>	• <b>109 LIBRARY</b>	165 SCREEN	<b>Z</b>
061 DRAWER	• <b>110 LIGHT</b>	166 SENSOR	224 ZONE (No.)
• <b>062 DRIVEWAY</b>	111 LINE	• <b>167 SERVICE</b>	• <b>225 ZONE</b>
• <b>064 DUCT</b>	• <b>113 LIVING</b>	• <b>168 SHED</b>	
	• <b>114 LOADING</b>		

**Note:** Bulleted (•) words in **boldface type** are those that are also available for use by the Phone Module. If using a phone module, and words other than these are selected for Alpha descriptors, the phone module will not provide annunciation of those words.

### CHARACTER (ASCII) CHART (For Adding Custom Words)

32 (space)	39 !	47 /	55 7	63 ?	71 G	79 O	87 W
40 (	41 )	48 0	56 8	64 @	72 H	80 P	88 X
42 *	43 +	49 1	57 9	65 A	73 I	81 Q	89 Y
44 ,	45 -	50 2	58 :	66 B	74 J	82 R	90 Z
46 .	47 /	51 3	59 ;	67 C	75 K	83 S	
		52 4	60 <	68 D	76 L	84 T	
		53 5	61 =	69 E	77 M	85 U	
		54 6	62 >	70 F	78 N	86 V	



# SECTION 10

## Creating Schedules

### About Schedules

The system provides up to 32 schedules, which can be used to control 11 types of system events at pre-defined times. Sixteen schedules are intended for use by the end-user, and sixteen are reserved for the installer. In addition, some events are also reserved for the installer only (listed in the “Enter Event” prompt paragraph below).

Start Scheduling mode by entering installer code + [#] + [6] [4] while in normal operating mode.

NOTE: The master code can only access schedules 01-16 and events 00-07.

The following prompts are displayed:

PROMPT	VALID ENTRIES	EXPLANATION
ENTER SCHED NO. 00=QUIT      00	<b>Schedule Number</b> 01-16 = end-user schedules 17-32 = installer-only schedules  [*] to continue	Enter the desired schedule number.  <b>NOTE:</b> Schedule 32 is automatically set for periodic test reports when the system time is initially set. See Periodic test report note in “Enter Event” prompt below.
ENTER EVENT   <b>NOTE:</b> Events 07 and 10 cause the keypad to beep every 30 seconds when messages are displayed. Stop the beeps and clear the display by pressing any key.	<b>Enter Event</b> 00 = clear event 01 = Relay On/Off 02 = User Access 03 = Latch Key Report to Pager 04 = Forced Stay Arming <sup>†</sup> 05 = Forced Away Arming <sup>†</sup> 06 = Auto Disarm 07 = Display “Reminder” 10 = Display custom words <sup>††</sup> 11 = Periodic Test Report <sup>†††</sup>  [*] to continue	Enter the desired event number for event you want to occur at a specified time. Events 10-11 are reserved for the installer only.  Latch key report (option 03) is sent to all pagers in the user’s partition and is active only when the system is armed (message sent is 777-7777). User must be enabled for paging (see User Attributes in <b>System Operation</b> section).  <sup>†</sup> Forced bypass is automatically enabled regardless of setting in field *23. <sup>††</sup> if selected, system displays custom words 8, 9, and 10 at defined time. Can be used as installer’s reminder message to the end user. <sup>†††</sup> A test report is automatically set for schedule 32 when the system time is initially set, and the first report is sent 12 hours later; thereafter the test report is sent every 28 days.
DEVICE NUMBER XX	<b>Device Number</b> 01-18 = device number  [*] to continue	This prompt appears if event “1” (relay on/off) was selected, otherwise it is skipped. Enter the physical device number as programmed in *79 Menu Mode, then press [*] to continue to the “Start” prompt. Device numbers 17 and 18 designate built-in triggers 1 and 2 respectively.
GROUP NUMBER X	<b>Group Number</b> 1-8 = group number  [*] to continue	This prompt appears if event “2” (user access) was selected. Otherwise it is skipped. Press [*] to continue to the “Start” prompt.
PARTITION X	<b>Partition</b> 0 = all partitions 1 = partition 1 2 = partition 2 3 = common  [*] to continue	This prompt appears if events “3-7,10” were selected. Otherwise it is skipped. Press [*] to continue to the “Start” prompt.

START SMTWTFSS
HH MMAM 0010000

**Start Time**  
01-12 = hour  
00-59 = minute  
0 = AM; 1 = PM  
Days = place "1" under days  
[\*] to continue

Enter the event's start time and days of the week to occur.  
To select days, position the cursor under the desired days using the [\*] key to move forward, then press "1" to select the day.

STOP SMTWTFSS
HH MMAM 0010000

**Stop Time**  
01-12 = hour  
00-59 = minute  
0 = AM; 1 = PM  
Days = place "1" under days  
[\*] to continue

Enter the event's stop time and days of the week to occur.  
To select days, position the cursor under the desired days using the [\*] key to move forward, then press "1" to select the day.  
This entry applies only to the following events:  
1 (relay on/off)  
2 (user access)  
3 (latch key report)

REPEAT OPTION
0-4 X

**Repeat Option**  
0 = do not repeat  
1 = repeat schedule weekly  
2 = repeat schedule biweekly  
(every other week)  
3 = repeat schedule every third  
week  
4 = repeat schedule every  
fourth week  
[\*] to continue

Enter the desired repeat option for this schedule.  
e.g., To make a schedule that happens everyday you would select all days with a repeat count of 1. To make a schedule that runs for one week then stops, select everyday with a repeat count of 0.

RANDOMIZE
0=NO 1=YES X

**Randomize**  
0 = no  
1 = yes  
[\*] to continue

Applies to events 01 and 11.  
If selected, the scheduled start and stop times will vary within 60 minutes of the "hour" time. For example, if a schedule is set to start at 6:15pm, it will do so the first time 6:15pm arrives, but on subsequent days it will start anytime between 6:00 and 6:59 p.m.

**NOTE:** Do not use the random option if the start and stop times are within the same "hour" setting, otherwise unpredictable results may occur (e.g., the randomized stop time may occur before the start time).

# System Communication

### Panel Communication with Central Station

When the panel calls the Central Station receiver, it waits to hear a “handshake” frequency from the receiver to confirm that the receiver is on-line and ready to receive its message. Once the panel hears the handshake it is programmed to listen for, it sends its message. The panel then waits for a “kissoff” frequency from the receiver acknowledging that the message was received and understood.

If the handshake frequency is not given or is not understood by the panel, the panel will not send its message. Once the handshake frequency is received and understood by the panel, the panel sends its message. If there is an error in the transmission (the receiver does not receive a “valid” message), the kissoff frequency is not given by the Central Station receiver.

The panel makes a total of eight attempts to the primary telephone number and eight attempts to the secondary telephone number (if programmed) to get a valid message through. If the panel is not successful after its numerous attempts, the keypad displays **COMM. FAILURE** (on alpha keypads) or **FC** (on fixed-word keypads).

### Report Code Formats

The following chart lists the formats and types of (handshake/kissoff) frequencies the panel supports.

FORMAT	HANDSHAKE	TRANSMITS DATA	KISSOFF	TRANSMIT TIME
Low Speed 4+2	1400 Hz	1900Hz (10PPS)	1400 Hz	Under 15 secs (Standard report)
Contact ID	1400–2300 Hz	DTMF (10 cps)	1400 Hz	Under 3 secs

The following table describes each format in greater detail.

FORMAT TYPE	DESCRIPTION
4+2 Format	Comprises a 4-digit subscriber number and 2-digit report code. Report codes are entered in Programming mode.
ADEMCO Contact ID Reporting Format	Comprises a 4- or 10-digit subscriber number (depending on format selected), 1-digit event qualifier (“new” or “restore”), 3-digit event code, and 3-digit zone number, user number, or system status number (see the following page).

### Ademco Contact ID®

The Ademco Contact ID® Reporting Format comprises the following:

- 4-digit subscriber number.
- 1-digit event qualifier (“new” or “restore”).
- 3-digit event code.
- 2-digit Partition No.
- 3-digit zone number, user number, or system status number (see the following page).

- Handshake: 1400–2300 Hz
- Data Transmission: DTMF (10 cps)
- Kissoff: 1400 Hz
- Transmit Time: Under 3 secs

Ademco Contact ID® Reporting takes the following format: CCCC Q EEE GG ZZZ

where:

CCCC = Customer (subscriber) ID

Q = Event qualifier, where:

E = new event , and R = restore

EEE = Event code (3 hexadecimal digits)

**Note:** For a complete list of event codes, refer to the central office receiver manual.

GG = Partition Number (system messages show “00”)

ZZZ = Zone/contact ID number reporting the alarm, or user number for open/close reports. System status messages (AC Loss, Walk Test, etc.) contain zeroes in the ZZZ location.

**TABLE OF CONTACT ID EVENT CODES**

Code	Definition
100	Medical Emergency (sent upon zone type 15 faults).
110	Fire Alarm
121	Duress
122	Alarm, 24-hour Silent
123	Alarm, 24-hour Audible
131	Alarm, Perimeter
132	Alarm, Interior
134	Alarm, Entry/Exit
135	Alarm, Day/Night
143	Alarm, Expansion Module
145	ECP Module cover tamper
146	Silent Burglary
150	Alarm, 24-Hour Auxiliary/Monitor zone
162	Carbon Monoxide
301	AC Power
302	Low System Battery/Battery Test Fail
305	System Reset (Log only)
309	Battery Test Failure
321	Bell/Siren Trouble
333	Trouble, Expansion Mod. Supervision
341	Trouble, ECP Cover Tamper
344	RF Receiver Jam
351	Telco Line Fault
353	Long Range Radio Trouble
373	Fire Loop Trouble
374	Exit Error Alarm
380	Global Trouble, Trouble Day/Night

Code	Definition
381	RF Sensor Supervision
382	Supervision Auxiliary Wire Zone
383	RF Sensor Tamper
384	RF Sensor Low-battery
393	Clean Me
401	Disarmed, Armed AWAY, Armed MAXIMUM
403	Schedule Arm/Disarm AWAY
406	Cancel by User
407	Remote Arm/Disarm (Downloading)
408	Quick Arm AWAY
409	Keyswitch Arm/Disarm AWAY
416	Panel Upload Completed
417	Panel Upload Failed
441	Disarmed/Armed STAY/INSTANT, Quick-Arm STAY/INSTANT
442	Keyswitch Arm/Disarm STAY
570	Bypass
601	Manually Triggered Dialer Test
602	Periodic Test
606	AAV to Follow
607	Walk Test Entered/Exited
623	Event Log 80% Full
625	Real-Time Clock was Changed (log only)
627	Program Mode Entry (log only)
628	Program Mode Exit (log only)
642	Latch Key (log only)
750 - 789	Reserved for Configurable Zone Type report codes (check with central station when using these codes)

SECTION 12  
**System Operation**

**Security Codes**

The system supports up to 48 security codes, which can each be assigned one of 5 authority levels. The authority level determines the functions each code can perform as follows:

**Authority Levels** (authority levels can be assigned to users 3-49 only; users 1 and 2 cannot be changed)

Level	User No.	Functions
Installer	01	perform all security functions except can disarm only if used to arm; can enter program mode; can change System Master code; cannot assign any other user codes; <b>Installer code expires</b> 4 hours after power up (see field *20)
System Master	02	(default 1234) only one system master code per system; can perform all security functions, add/delete users in either partition, change system master code, view event log, set system clock, program keypad macro, program scheduled events, activate output devices (triggers/relays)
Partition Master (default)	P1 = 03 P2 = 33	same as Master, except add/delete users limited to assigned partition only, (these users can be assigned different authority levels; any user can be assigned the partition master authority level)
0-User	03-49	perform security functions (arm, disarm, etc.) only; cannot add/delete users, view event log, set system clock or program scheduled events
1-Arm Only	see "user"	arm system only
2-Guest	see "user"	can disarm the system only if it was used to arm the system
3-Duress	see "user"	performs security functions, but also silently sends a duress message to the central station; reports as duress code user number
4-Partition Master	see "user"	See Partition Master paragraph above; used to assign other user numbers as partition masters

Refer to the user guide for detailed procedures on adding/deleting security codes and changing user attributes.

The following is a brief description of how to add user codes.

Changing the System Master code...

- Using Installer code: Installer code + [8] + 02 + new code
- Using current System Master code: System Master code + [8] + 02 + new code + new code again

Adding a User Code: Master code + [8] + 2-digit user no. + user's code

Deleting a User Code: Master code + [8] + 2-digit user no. + [#] [0]

Assigning Attributes: Master<sup>†</sup> code + [8] + 2-digit user no. + [#] [attribute no.] + value

Attributes:	Values
1 = Authority Level	0-4 (see Authority Level table above)
2 = Access Group	0-8 (0 = not assigned to a group)
3 = Active Partition(s) for this user;	1, 2, 3 (common) Enter partitions consecutively if more than one and press [#] to end the entries.
4 = RF Zone No.	Assigns user number to button type zone for arm/disarm. enter the zone number assigned to a button on the keyfob that will be used for arming/disarming by this user. <b>Keyfob must be enrolled in system first; see <i>Wireless Key Programming Templates</i></b> section.
5 = Open/Close Paging	1 for yes, 0 for no

## Keypad Functions

The following is a brief list of system commands. For detailed information concerning system functions, refer to the User's Manual. For AUI users, refer to the separate AUI User's Guide.

Function	Description
Silence alarms	Pressing any key will silence the keypad sounder for 10 seconds. Disarming the system will silence both keypad and external sounders.
Quick Arm	If enabled (field *21), you can press [#] in place of the system's security code, plus the desired arming key (Away, Stay, Night-Stay, Instant, Maximum)
Single-Button arming	If programmed (*57 Function Key menu mode), lettered keys A-D can be used for arming, using options 3-AWAY, 4-STAY, 5-NIGHT-STAY, or 6-Step-Arming. If used, no security code is required to arm the system.
Alarm Memory	When the system is disarmed, any zones that were in an alarm condition during the armed period will be displayed. To clear this display, simply repeat the disarm sequence (enter the security code and press the OFF key) again.
Arming Away	Enter code + AWAY [2] or simply press appropriate lettered key on the keypads (see "Single-Button Arming" above). If the "Auto-Stay Arm" feature is enabled (field *84) and the entry/exit door <b>is not</b> opened and closed within the programmed exit delay time, the system will automatically arm in STAY mode if armed from a wired keypad (non-RF device). If the door <b>is</b> opened and closed within the exit delay period, the system arms in AWAY mode.
Arming Stay	Enter code + STAY [3] or simply press appropriate key on the keypads (see "Single-Button Arming" above). See "Arming Away" above for Auto-Stay arming feature.
Arming Night-Stay	Enter code + STAY [3] + STAY [3] or simply press appropriate key on the keypads (see "Single-Button Arming" above). The Night-Stay feature is disabled if field *199 is set to "1" (e.g. if using a FA245RF keypad)
Arming Instant	Enter code + INSTANT [7].
Arming Maximum	Enter code + MAXIMUM [4]. See Auto-Stay Arm description in arming Away above. Operates similar except arms INSTANT instead of STAY.
Disarming	Enter code + OFF [1]. If entry delay or an alarm is active, you do not need to press OFF.
Bypassing Zones	Enter code + BYPASS [6] + zone number(s).
Forced (Quick) Bypass	To automatically bypass all faulted zones, use the "Quick Bypass" method. Enter code + BYPASS + [#], then wait for all open zones to be displayed. Arm when display indicates "ZONE BYPASSED" and "READY TO ARM".
Chime Mode	Enter code + CHIME [9]. To turn chime off, enter code + CHIME again. Quick Chime Mode: [#] + [9] turns chime on; [#] + [9] again turns chime off
Activate Output Devices	If relay outputs (via a 4204, or 4229), or Powerline Carrier devices are used, two keypad entries available to the user are included. If programmed, these entries can be used to manually activate or deactivate the device(s) for starting or stopping some action, such as turning lights on or off, etc. These keypad entries are: [Security Code] + # + 7 + [2-digit Device #] activates (starts) that device. [Security Code] + # + 8 + [2-digit Device #] deactivates (stops) that device.

### SUMMARY OF ARMING MODES

Arming Mode	Features for Each Arming Mode			
	Exit Delay	Entry Delay	Perimeter Armed	Interior Armed
AWAY	Yes	Yes	Yes	Yes
STAY	Yes	Yes	Yes	No
NIGHT-STAY	Yes	Yes	Yes	only those zones listed in Night-Stay zone list
INSTANT	Yes	No	Yes	No
MAXIMUM	Yes	No	Yes	Yes

## Panic Keys

There are three Panic keys (A, B, and C) that, if programmed, can be used to manually initiate alarms and send a report to the central station.

Each key can be programmed for 24-hour Silent, 24-hour Audible, Fire, or Personal Emergency responses.

The programmed Panic response is activated when the appropriate key is pressed for at least 2 seconds.

The Panic keys are identified by the system as follows:

Keys	Displayed as Zone
[A] (*/1)	95
[B] (*/#)	99
[C] (3/#)	96

**IMPORTANT:** For a Silent panic function (if programmed) to be of practical value, you must program a report code for the zone and the system must be connected to a central station.

## Setting the Real-Time Clock

The keypad displays “Clock Not Set” (alpha keypads) or “C5” (fixed-word keypads) upon power up if the clock is not set. This message toggles with other system messages until the clock is set.

Set the time and date by doing the following:

1.     +[#] + [6] [3]  
(Security Code)
2. Press [\*] when the time/date is displayed.  
A cursor appears under the first digit of the hour.  
*To move cursor ahead, press [\*]. To go back, press [#].*
  - Enter the 2-digit hour setting.
  - Enter the 2-digit minute setting.
  - Press [1] for PM or [2] for AM.
  - Enter the last two digits of the current year.
  - Enter the 2-digit month setting.
  - Enter the 2-digit day setting.
3. To exit, press [\*] when cursor is at the last digit, or wait 10 seconds.

Alpha Display:

```
DISARMED
READY TO ARM
```

```
TIME/DATE SAT
04:04PM 10/17/00
```

Current time display

```
TIME/DATE SAT
04:04P2000/10/17
```

Time/date editing display

**TIME ZONE NOTE:** Use field \*83 Time Zone Setting to select the appropriate time zone in which the control is installed. This setting provides proper downloader time synchronization if downloading from a different time zone.

**TEST REPORT NOTE:** When the system clock is set for the first time, a test report is automatically set for schedule 32. A test report is sent 12 hours later; thereafter the test report is sent every 28 days.

## Various System Trouble Displays

Alpha Display	Fixed Disp.	Meaning
CANCELED ALARM	CA	will appear if an exit or interior zone contained a fault during closing at the time the Exit Delay ended (e.g., exit door left open), but the system was disarmed during the Entry Delay time. The alarm sounder and keypad sound continuously, but stop when the system is disarmed. No message will be transmitted to the central station.
EXIT ALARM	EA	will appear when the Exit Delay ends if an exit or interior zone contained a fault during closing. The alarm sounder and keypad sound continuously until the system is disarmed (or timeout occurs). An "Exit Alarm" message is sent to the central station. Also results if an alarm from an exit or interior zone occurs within 2 minutes after the end of an Exit Delay.
CHECK	CHECK	indicates that a problem exists with the displayed zone(s) and requires attention.
CLOCK NOT SET	C5	indicates the system's real-time clock has not been set.
ALARM 1xx FAULT 1xx CHECK 1xx	1xx 1xx 1xx 91	indicates that communication between control and a zone expander or wireless receiver is interrupted, where "xx" is the device address. Check the wiring and DIP switch settings on the units. If field *199 is set to "1," all ECP module problems are displayed as "91." If there are wireless sensors in the system, the Check condition may also be caused by some change in the environment that prevents the receiver from receiving signals from a particular sensor.
SYSTEM LO BAT	BAT	with no zone number indicates that the system's main standby battery is weak.
LO BAT	BAT	with a zone number and a once-per-minute beeping at the keypad indicates that a low-battery condition exists in the wireless sensor displayed (zone "00" indicates a wireless keypad). If the battery is not replaced within 30 days, a "CHECK" display may occur. Note: Some wireless sensors contain a non-replaceable long-life battery which requires replacement of the entire unit at the end of battery life (e.g., Nos. 5802, 5802CP).
TELCO FAULT	94	Telephone Line Failure, indicates that a monitored telephone line (if programmed in field *92) has been cut or disconnected. Depending on how the system was programmed, the keypad may also produce a trouble sound, and the external sounder may be activated. Silence by entering installer code + OFF.
Busy-Standby	dl	If this remains displayed for more than 1 minute, the system is disabled.
Modem Comm	CC	The system is in communication with the central station for change of function or status verification.
no display	no display	Power Failure If there is no keypad display at all and the LEDs are unlit, operating power (AC and battery) for the system has stopped and the system is inoperative. If the message "AC LOSS" (Alpha display keypads) or "NO AC" (Fixed-Word display keypads) is displayed, the keypad is operating on battery power only. If the battery standby capacity is used up during a prolonged AC power outage, the control's power will shut down to minimize deep discharge of the battery.
Comm. Failure	FC	A communication failure has occurred.
Open Circuit	OC	The keypad is not receiving signals from the control and sees an open circuit.
Long Rng Trbl	bF	Backup LRR communication failure.
Bell Failure	70	Bell supervision failure.
RCVR Jam	90	RF jam detected.
KEYPAD LOW BAT	00 BAT	Wireless keypad low battery
Phone Okay	Cd	The dialer test has been successful (CID code 601).
Dialer Off	dO	The dialer is disabled.
Test in Progress	dd	Walk test mode is active(CID code 607).
Upload Completed	dC	The upload or download session was completed.
Upload Failed	dF	The upload or download session failed before completion.



### About Test Procedures

After the installation is complete, you should perform the following tests:

- System Test: Checks that all zones have been installed properly and the system properly responds to faults.
- Dialer Test: Checks that the phone connection to the central station is working properly.
- Go/No Go Test: Checks that transmissions can be received from transmitters. Should be performed before permanently mounting transmitters.
- RF Sniffer Mode: Checks that RF transmitter serial numbers have been properly entered into the system.
- Battery Tests: Automatic battery tests are performed by the system. See Automatic Battery Test paragraph for details.

---

### System Test

With the system in the disarmed state, check that all zones are intact (not faulted). Doors and windows with contacts should be closed, PIRs should be covered (use a cloth to mask them temporarily if necessary). If a “NOT READY” message is displayed, press [\*] to display the faulted zone(s). Restore faulted zone(s) if necessary, so that the “READY” message is displayed.

1. Enter Installer Code + 5 [TEST] , then press “0” at the prompt to start Walk Test mode.

1=DIAL, 0=WALK

(no special display on Fixed-Word keypads)

The following will be displayed:

TEST IN PROGRESS

(“dd” displayed on Fixed-Word Display Keypads)

A Contact ID report will also be sent (code 607)

2. Upon entering the system test mode, the outside sounder should sound for 1 second. If the backup battery is discharged or missing, the sounder may not turn on and a “LOW BATTERY” report will be transmitted with a “TEST” report. The keypad will beep about every 40 seconds as a reminder that the system is in the Test mode.  
**NOTE:** Wireless motion detectors (Passive Infrared units) will send signals out only if they have been inactive for 3 minutes (conserves battery life).
3. Test all sensors using the procedure described in the User’s Guide “Testing the System” section.
4. After checking sensors, turn off the test mode by entering installer code + OFF.

**NOTE:** Test mode automatically ends after 4 hours. During the final 5 minutes (after 3 hours 55 minutes of Test mode), the keypad emits a double-beep every 30 seconds to alert that the end of Test mode is nearing.

---

### Checking Transmitter Enrollment (Sniffer Mode)

Use this mode to verify that all transmitters have been properly programmed. Make sure both partitions are disarmed before trying to enter this mode, since this is a system-wide command.

1. Press [Installer code] + [#] + 3.

**Note:** If the communicator is in the process of sending a report to the central station, the system will not go into the Sniffer mode. If so, wait a few minutes, and try again.

The keypads in both partitions will display all zone numbers of wireless units (in both partitions) programmed into the system. Fault each transmitter in turn, causing each one to send a signal. As the system receives a signal from each of the transmitters, the zone number of that transmitter disappears from the display.

2. After all transmitters have been checked, exit the sniffer mode by keying [Installer code] + OFF.

**IMPORTANT:** Sniffer mode does not automatically expire. You must manually exit Sniffer mode (by entering [**Installer code**] + **OFF**) to return to normal operation.

#### Notes:

- All BR type units must physically be activated to clear the display.
- When **one** button of a transmitter (RF, UR, or BR) is activated, all zones assigned to other buttons on that transmitter are cleared. This also applies to 5816 and 5817 transmitters, which have multiple loops (zones).
- Any transmitter that is not “enrolled” will not turn off its zone number.

---

### Go/No Go Test Mode

The Go/No Go Test verifies adequate RF signal strength from the proposed transmitter location, and allow you to reorient or relocate transmitters if necessary, before mounting the transmitters permanently. This mode is similar to the Transmitter Test mode, except that the wireless receiver gain is reduced. This will enable you to make sure that the RF signal from each transmitter is received with sufficient signal amplitude when the system is in the normal operating mode.

1. Enter [Installer code] + [#] + 4 from the partition being tested. For multi-partition systems, repeat this test for each partition.
2. After you have placed transmitters in their desired locations and the approximate length of wire to be run to sensors is connected to the transmitter's screw terminals (if used), fault each transmitter. Do not conduct this test with your hand wrapped around the transmitter, as this will cause inaccurate results.
  - a. The keypad will beep three times to indicate signal reception and display the appropriate zone number.
  - b. If the keypad does not beep, you should reorient or move the transmitter to another location. Usually a few inches in either direction is all that is required.
4. If each transmitter produces the proper keypad response when it is faulted, you can then permanently mount each of the transmitters according to the instructions provided with them.
5. Exit the Go/No Go Test mode by entering: [any user code (partition-specific)] + OFF.

---

## Dialer Communication Test

1. Enter Installer Code + 5 [TEST], then press “1” at the prompt to start the Dialer Test.

1=DIAL, 0=WALK

(no special display on Fixed-Word keypads)

The following will be displayed (accompanied by 2 beeps) if test is successful:

PHONE OKAY

(“Cd” displayed on Fixed-Word Display Keypads)

A Contact ID report will also be sent (code 601)

If the dialer test is unsuccessful, the following is displayed:

COMM FAILURE

(“FC” displayed on Fixed-Word Display Keypads)

2. Enter Installer code + OFF to clear the display and exit.

---

## Automatic Standby Battery Tests

1. An automatic test is conducted every 3 minutes to ensure that a standby battery is present and properly connected. If a battery is not present or is not properly connected, a “LOW BATTERY” message is displayed and, if so programmed, will be reported to the central station.
2. A battery capacity test is automatically conducted for 2 minutes every 4 hours, beginning 4 hours after exiting the Programming mode or after powering up the system. In addition, entry into the Test mode will also cause a battery capacity test to be initiated. If the battery cannot sustain a load, a “Low Battery” message is displayed and, if so programmed, will be reported to the central station.



# Specifications & Accessories

## SECURITY CONTROL

1. **Physical:** 12-1/2" W x 14-1/2" H x 3" D (318mm x 368mm x 76mm)
2. **Electrical:**  
 VOLTAGE INPUT: 16.5VAC from plug-in 25VA transformer, Ademco No. 1321 (in U.S.A.)  
 RECHARGEABLE BACKUP BATTERY: 12VDC, 4AH (sealed lead acid type). Charging Voltage: 13.8VDC.  
 ALARM SOUNDER: 12V, 2.0 Amp output can drive 12V BELLS or can drive one or two 702 (series connected) self-contained 20-watt sirens. Do **not** connect two 702s in parallel.  
 AUXILIARY POWER OUTPUT: 12VDC, 600mA max.  
**Note:** For UL installations, Alarm Sounder plus Auxiliary Power currents should not exceed 600mA total.
3. **Communication:**  
 FORMAT SUPPORTED:  
 ADEMCO Express: 10 characters/sec, DTMF (TouchTone) Data Tones, 1400/2300Hz ACK, 1400Hz KISSOFF.  
 ADEMCO Low Speed: 10 pulses/sec, 1900Hz Data Tone, 1400Hz ACK/KISSOFF.  
 Radionics/SESCOA: 20 pulses/sec, 1800Hz Data Tone, 2300Hz ACK/KISSOFF.  
 Can report 0-9, B-F  
 Ademco Contact ID 10 characters/sec., DTMF (TouchTone) Data Tones, 1400/2300Hz ACK, 1400Hz KISSOFF.  
 LINE SEIZE: Double Pole  
 RINGER EQUIVALENCE: 0.1B  
 FCC REGISTRATION No.: 5GBUSA-44003-AL-E
4. **Maximum Zone Resistance:** Zones 1-8 = 300 ohms excluding EOLR standard zones

## COMPATIBLE DEVICES

- Keypads:** FA245KP, FA260KP Fixed-Word Keypads, FA560KP Alpha Keypad, FA245RF, FA260RF, FA700KP Touch Screen Keypad, Symphony Advanced User Interface
- Wireless Receivers:** 5881L/5882L: accepts up to 8 transmitters  
 5881M/5882M: accepts up to 16 transmitters  
 5881H/5882H: accepts up to system maximum transmitters  
 5800TM Transmitter Module (used with 5827BD Wireless 2-Way Keypad)
- Zone Expansion:** 4219 WIRED EXPANSION MODULE  
 4229 WIRED EXPANSION/RELAY MODULE
- Relay Module:** 4204 RELAY MODULE
- Phone Modules:** FA4285 PHONE MODULE  
 FA4286VIP PHONE MODULE
- Long Range Radio** 7835C/7845C

**2-Wire Smoke Detector:**

<b>Detector Type</b>	<b>System Sensor Model No.</b>
Photoelectric w/heat sensor, direct wire	2300TB
Photoelectric, direct wire	2400
Photoelectric w/heat sensor, direct wire	2400TH
Photoelectric	2451 w/B401B base
Photoelectric w/heat sensor	2451TH w/B401B base
Ionization, direct wire	1400
Ionization	1451 w/B401B base
Photoelectric duct detector	2451 w/DH400 base
Ionization duct detector	1451D w/DH400 base H
Low-profile, Photoelectric, w/135°F thermal	2100T
Low-profile, Ionization type, direct wire	1100

**Transformers:**

1321: 16.5VAC, 25VA Plug-In Transformer (No. 1321CN in Canada)  
1361X10: 16.5VAC, 40VA Powerline Carrier Device Interface AC Transformer

**Sounders:**

Ademco AB-12M 10" Motorized Bell & Box  
Ademco 1011BE12M 10" Motorized Bell & Box  
Ademco 702 Outdoor Siren  
Ademco 719 2-Channel Siren  
Ademco 747 Indoor Siren  
Ademco 747UL Indoor Siren  
Ademco 744 Siren Driver  
Ademco 745X3 Voice Siren Driver  
Ademco 705-820 5-inch Round Speaker  
Ademco 713 Speaker  
System Sensor PA400B (beige)/; PA400R (red) Indoor Piezo Sounder

## 5800 Series Transmitter Input Loop Identification

- All of the transmitters illustrated below have one or more unique factory assigned input (loop) ID codes. Each of the input loops requires its own programming zone (e.g., a 5804's four inputs require four programming zones).

- **Transmitter inputs entered as:**

**"RF" (Supervised RF) Type** send periodic check-in signals, as well as fault, restore and low battery signals. The transmitter must remain within the receiver's range.

**"UR" (Unsupervised RF) Type** send all the signals that the "RF" Type does, but the control does not supervise the check-in signals. The transmitter may, therefore, be carried off-premises.

**"BR" (Unsupervised Button RF) Type** only send fault signals. They do not send restore or check-in signals. They will indicate a low battery condition when tested or activated normally. The transmitter may be carried off-premises.

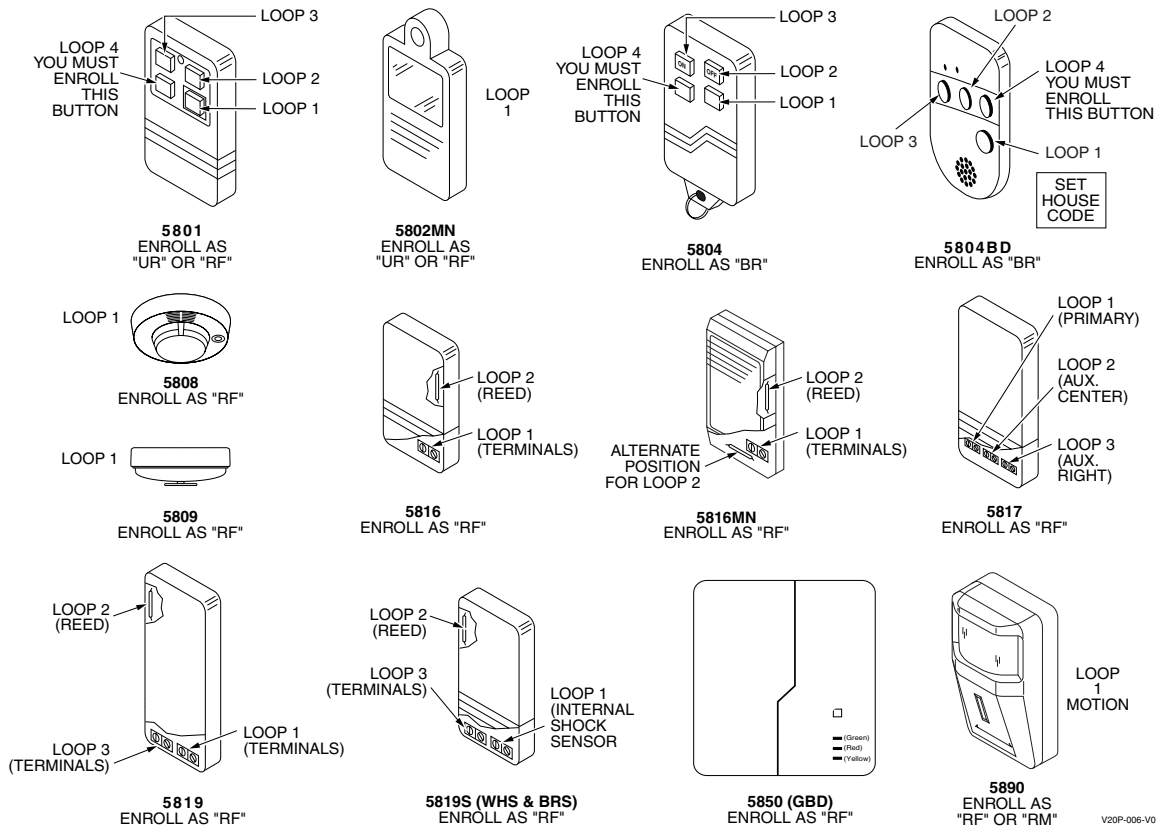

**NOTE:** For information on any transmitter not shown above, refer to the instructions accompanying that transmitter for details regarding loop numbers, etc.

**UL NOTE:** The following transmitters are not intended for use in UL installations:

5802MN, 5802MN2, 5804, 5804BD, 5814, 5816TEMP, 5819, 5819WHS & BRS, and 5850.

### Compatible 5800 Series Transmitters Table

Also refer to *Appendix A* for transmitter input loops/button locations.

Model	Product	Enter as Input Device Type	Description
5801	Wireless Panic Transmitter	UR or RF	<ul style="list-style-type: none"> <li>• Has four pushbuttons, each with a unique input (loop) code.</li> <li>• Programmable responses (e.g., Panic, Arm-Stay, Arm-Away, Disarm, etc.)</li> </ul>
5802	Pendant (Personal Emergency Transmitter)	BR Only	<ul style="list-style-type: none"> <li>• Has single pushbutton.</li> <li>• Usually programmed for response type of 24-Hr audible or 24-Hr Silent (other zone responses are possible).</li> </ul>
5802CP	Belt Clip (Personal Emergency)	BR Only	Same as 5802.
5802MN	Miniature (Personal Emergency Transmitter)	UR or RF	<ul style="list-style-type: none"> <li>• Has single pushbutton.</li> <li>• Usually programmed for a response type of 24-Hr Audible or 24-Hr Silent (other zone responses are possible).</li> </ul>
5804	Wireless Key Transmitter	BR Only	<ul style="list-style-type: none"> <li>• Has four pushbuttons, each with a unique input (loop) code.</li> <li>• Programmable responses (e.g., Arm-Stay, Arm-Away, Disarm, etc.)</li> </ul>
5804BD	Bi-Directional Wireless Key	BR	<ul style="list-style-type: none"> <li>• House ID must be set.</li> <li>• Requires 5800TM Transmitter Module.</li> <li>• Can indicate system status via its 2 LEDs and built-in sounder.</li> <li>• Has four pushbuttons, each with a unique input (loop) code.</li> <li>• Operates the system similarly to wired keypads.</li> </ul>
5806 5807 5808	Wireless Photoelectric Smoke Detectors	RF	One-piece smoke detectors with a built-in transmitter.
5809	Heat Detector	RF	One-piece rate-of-rise heat detector with a built-in transmitter.
5816 5816MN	Door/Window Transmitters	RF	Has two unique input (loop) codes: one for a wired closed circuit contact loop; the other for a built-in reed switch (used with a magnet).
5816 TEMP	Low-Temperature Sensor	RF	Transmits a fault condition when temperature drops below 45°F.
5817	Multi-Point Universal Transmitter	RF	Has three unique input (loop) codes: one for a “Primary” contact loop with programmable options; the others for two “auxiliary” closed circuit contact loops.
5818	Recessed Transmitter	RF	<ul style="list-style-type: none"> <li>• Reed switch magnetic contact sensor; easily hidden in the frame and edge of a door or window.</li> <li>• Has a single unique input (loop) code.</li> </ul>



Model	Product	Enter as Input Device Type	Description
5819	Shock Processor Transmitter	RF	<ul style="list-style-type: none"> <li>Connects to externally mounted inertia-type shock detector (not supplied).</li> <li>Has built-in tampered cover switch.</li> <li>Has 3 unique input (loop) codes: <ul style="list-style-type: none"> <li><i>Loop 1:</i> Terminals for a wired, N.C. sensor loop.</li> <li><i>Loop 2:</i> For a closed circuit contact loop using the built-in reed switch in conjunction with a magnet.</li> <li><i>Loop 3:</i> Terminals for a wired, closed circuit contact loop.</li> </ul> </li> </ul>
5819WHS 5819BRS	Shock Processor Transmitter	RF	<ul style="list-style-type: none"> <li>Has built-in shock sensor.</li> <li>Has built-in tampered cover switch.</li> <li>Has 3 unique input (loop) codes: <ul style="list-style-type: none"> <li><i>Loop 1:</i> Built-in shock sensor loop wired to TB1 (normally closed).</li> <li><i>Loop 2:</i> For a closed circuit contact loop using the built-in reed switch in conjunction with a magnet.</li> <li><i>Loop 3:</i> Externally wired, closed circuit contact loop connected to TB2.</li> </ul> </li> </ul>
5827	Wireless Keypad	Uses House ID only	<ul style="list-style-type: none"> <li>Can be used to turn the burglary protection on and off.</li> <li>Features the same built-in panic functions as wired keypads.</li> <li>The keypad is identified as zone "00" on wired keypads when it transmits with a low battery.</li> </ul>
5827BD	Wireless Two-Way Keypad	Uses House ID only	<ul style="list-style-type: none"> <li>Requires 5800TM Transmitter Module.</li> <li>Operates the system similarly to wired keypads, including panic functions.</li> <li>Can indicate system status via its 3 LEDs and sounder.</li> <li>Includes 3 panic keys.</li> </ul>
5849	Glassbreak Detector	RF	<ul style="list-style-type: none"> <li>House ID must also be set.</li> <li>Requires both sound and shock of breaking glass to cause alarm to be transmitted.</li> </ul>
5890	PR Detector <sup>†</sup>	RF	<p>Dual-element passive infrared detector/transmitter with built-in selectable pulse count.</p> <p><b>Note:</b> There is a 3-minute lockout between fault transmissions to conserve battery life.</p>
5899	Magnets		Package of 4 magnets for use with 5816 and 5817 transmitters.



# Regulatory Agency Statements

## RADIO FREQUENCY EMISSIONS

### Federal Communications Commission (FCC) Part 15

This device complies with part 15 of the FCC rules. Operation is subject to the following two conditions: (1) This device may not cause harmful interference, and (2) this device must accept any interference received, including interference that may cause undesired operation.

### Industry Canada

This Class B digital apparatus complies with Canadian ICES-003.  
Cet appareil numérique de la classe B est conforme à la norme NMB-003 du Canada.

## TELEPHONE/MODEM INTERFACE

### FCC Part 68

This equipment complies with Part 68 of the FCC rules. On the front cover of this equipment is a label that contains the FCC registration number and Ringer Equivalence Number (REN). You must provide this information to the telephone company when requested.

This equipment uses the following USOC jack: RJ31X

This equipment may not be used on telephone-company-provided coin service. Connection to party lines is subject to state tariffs. This equipment is hearing-aid compatible.

### Industry Canada

**NOTICE:** The Industry Canada Label identifies certified equipment. This certification means that the equipment meets telecommunications network protective, operational and safety requirements as prescribed in the appropriate Terminal Equipment Technical Requirements document(s). The Department does not guarantee the equipment will operate to the user's satisfaction.

Before installing this equipment, users should ensure that it is permissible to be connected to the facilities of the local telecommunications company. The equipment must also be installed using an acceptable method of connection. The customer should be aware that compliance with the above conditions may not prevent degradation of service in some situations.

Repairs to certified equipment should be coordinated by a representative designated by the supplier. Any repairs or alterations made by the user to this equipment, or equipment malfunctions, may give the telecommunications company to request the user to disconnect the equipment.

Users should ensure for their own protection that the electrical ground connections of the power utility, telephone lines and internal metallic water pipe system, if present, are connected together. This precaution may be particularly important in rural areas.

**Caution:** Users should not attempt to make such connections themselves but should contact appropriate electric inspection authority, or electrician, as appropriate.

### Ringer Equivalence Number Notice:

The **Ringer Equivalence Number** (REN) assigned to each terminal device provides an indication of the maximum number of terminals allowed to be connected to a telephone interface. The termination on an interface may consist of any combination of devices subject only to the requirement that the sum of the Ringer Equivalence Numbers of all the devices does not exceed 5.

## Industrie Canada

**AVIS:** L'étiquette d'Industrie Canada identifie le matériel homologué. Cette étiquette certifie que le matériel est conforme aux normes de protection, d'exploitation et de sécurité des réseaux de télécommunications, comme le prescrivent les documents concernant les exigences techniques relatives au matériel terminal. Le Ministère n'assure toutefois pas que le matériel fonctionnera à la satisfaction de l'utilisateur.

Avant d'installer ce matériel, l'utilisateur doit s'assurer qu'il est permis de le raccorder aux installations de l'entreprise locale de télécommunication. Le matériel doit également être installé en suivant une méthode acceptée de raccordement. L'abonné ne doit pas oublier qu'il est possible que la conformité aux conditions énoncées ci-dessus n'empêche pas la dégradation du service dans certaines situations.

Les réparations de matériel homologué doivent être coordonnées par un représentant désigné par le fournisseur. L'entreprise de télécommunications peut demander à l'utilisateur de débrancher un appareil à la suite de réparations ou de modifications effectuées par l'utilisateur ou à cause de mauvais fonctionnement.

Pour sa propre protection, l'utilisateur doit s'assurer que tous les fils de mise à la terre de la source d'énergie électrique, de lignes téléphoniques et des canalisations d'eau métalliques, s'il y en a, sont raccordés ensemble. Cette précaution est particulièrement importante dans les régions rurales.

**Avertissement :** L'utilisateur ne doit pas tenter de faire ces raccordements lui-même; il doit avoir recours à un service d'inspection des installations électriques, ou à un électricien, selon le cas.

**AVIS : L'indice d'équivalence de la sonnerie** (IES) assigné à chaque dispositif terminal indique le nombre maximal de terminaux qui peuvent être raccordés à une interface. La terminaison d'une interface téléphonique peut consister en une combinaison de quelques dispositifs, à la seule condition que la somme d'indices d'équivalence de la sonnerie de tous les dispositifs n'excède pas 5.

### UL NOTICES

1. Entry Delay No. 1 and No. 2 (fields \*35, \*36) cannot be greater than 30 seconds for UL Residential Burglar Alarm installations, and entry delay plus dial delay should not exceed 1 minute. For UL Commercial Burglar Alarm installations, total entry delay may not exceed 45 seconds.
2. For UL Commercial Burglar Alarm (Grade AA) and UL Residential Burglar Alarm installations with line security, total exit delay time must not exceed 60 seconds. For UL Burglar Alarm installations without line security (Grade A), total exit delay time must not exceed 120 seconds.
3. The maximum number of reports per armed period (field \*93) must be set to "0" (unlimited) for UL installations.
4. Periodic testing (see scheduling mode) must be at least every 24 hours.
5. Alarm Sounder plus Auxiliary Power currents must not exceed 600mA total for UL installations (Aux power 500mA max.).
6. All partitions must be owned and managed by the same person(s).
7. All partitions must be part of one building at one street address.
8. If used, the audible alarm device(s) must be placed where it/they can be heard by all partitions.
9. For UL commercial burglar alarm installations the control unit must be protected from unauthorized access. The tamper switch installed to protect the control unit enclosure door is suitable for this purpose.
10. Remote downloading without an alarm company technician on-site (unattended downloading) is not permissible for UL installations.
11. Auto-disarming is not a UL Listed feature.

### Notes for SIA Installations

1. As SIA limits for delay of alarm reporting and sounding can exceed UL limits for commercial and residential applications, the following UL requirements per UL681 are provided:  
The maximum time that a control unit shall be programmed to delay the transmission of a signal to a remote monitoring location, or to delay the energizing of a local alarm sounding device to permit the alarm system user to enter and disarm the system, or to arm the system and exit shall not exceed:
  - a) 60 seconds for a system with standard line security or encrypted line security,
  - b) 120 seconds for a system without standard line security or encrypted line security, or
  - c) 120 seconds for a system that does not transmit an alarm signal to a remote monitoring location.
2. \*34 Exit Delay: minimum exit delay is 45 seconds
3. \*35/\*36 Entry Delay 1 and 2: minimum entry delay is 30 seconds.
4. \*39 Power Up in Previous State: must be "1," power up in previous state
5. \*40 PABX Access Code or Call Waiting Disable: If call waiting is used, call waiting disable option in field \*91 must be set.
6. \*50 Burglary Dial Delay: delay must be minimum of 30 seconds.
7. \*59 Exit Error Alarm Report Code: Always enabled.
8. \*69 Recent Closing Report Code: Always enabled.
9. \*91 Option Selection: Exit Delay option should be enabled. If call waiting is used, Call Waiting Disable must be set to "1" (enabled).
10. \*93 No. reports in Armed Period: Must be set for 1 or 2 report pairs.

---

**- NOTES -**

**- NOTES -**

---

**- NOTES -**

**- NOTES -**



---

**- NOTES -**

**- NOTES -**

# Limitations and Warranty

## WARNING THE LIMITATIONS OF THIS ALARM SYSTEM

While this System is an advanced design security system, it does not offer guaranteed protection against burglary, fire or other emergency. Any alarm system, whether commercial or residential, is subject to compromise or failure to warn for a variety of reasons. For example:

- Intruders may gain access through unprotected openings or have the technical sophistication to bypass an alarm sensor or disconnect an alarm warning device.
- Intrusion detectors (e.g., passive infrared detectors), smoke detectors, and many other sensing devices will not work without power. Battery-operated devices will not work without batteries, with dead batteries, or if the batteries are not put in properly. Devices powered solely by AC will not work if their AC power supply is cut off for any reason, however briefly.
- Signals sent by wireless transmitters may be blocked or reflected by metal before they reach the alarm receiver. Even if the signal path has been recently checked during a weekly test, blockage can occur if a metal object is moved into the path.
- A user may not be able to reach a panic or emergency button quickly enough.
- While smoke detectors have played a key role in reducing residential fire deaths in the United States, they may not activate or provide early warning for a variety of reasons in as many as 35% of all fires, according to data published by the Federal Emergency Management Agency. Some of the reasons smoke detectors used in conjunction with this System may not work are as follows. Smoke detectors may have been improperly installed and positioned. Smoke detectors may not sense fires that start where smoke cannot reach the detectors, such as in chimneys, in walls, or roofs, or on the other side of closed doors. Smoke detectors also may not sense a fire on another level of a residence or building. A second floor detector, for example, may not sense a first floor or basement fire. Finally, smoke detectors have sensing limitations. No smoke detector can sense every kind of fire every time. In general, detectors may not always warn about fires caused by carelessness and safety hazards like smoking in bed, violent explosions, escaping gas, improper storage of flammable materials, overloaded electrical circuits, children playing with matches, or arson. Depending on the nature of the fire and/or location of the smoke detectors, the detector, even if it operates as anticipated, may not provide sufficient warning to allow all occupants to escape in time to prevent injury or death.
- Passive Infrared Motion Detectors can only detect intrusion within the designed ranges as diagrammed in their installation manual. Passive Infrared Detectors do not provide volumetric area protection. They do create multiple beams of protection, and intrusion can only be detected in unobstructed areas covered by those beams. They cannot detect motion or intrusion that takes place behind walls, ceilings, floors, closed doors, glass partitions, glass doors, or windows. Mechanical tampering, masking, painting or spraying of any material on the mirrors, windows or any part of the optical system can reduce their detection ability. Passive Infrared Detectors sense changes in temperature; however, as the ambient temperature of the protected area approaches the temperature range of 90° to 105°F (32° to 40°C), the detection performance can decrease.
- Alarm warning devices such as sirens, bells or horns may not alert people or wake up sleepers if they are located on the other side of closed or partly open doors. If warning devices are located on a different level of the residence from the bedrooms, then they are less likely to waken or alert people inside the bedrooms. Even persons who are awake may not hear the warning if the alarm is muffled by noise from a stereo, radio, air conditioner or other appliance, or by passing traffic. Finally, alarm warning devices, however loud, may not warn hearing-impaired people.
- Telephone lines needed to transmit alarm signals from a premises to a central monitoring station may be out of service or temporarily out of service. Telephone lines are also subject to compromise by sophisticated intruders.
- Even if the system responds to the emergency as intended, however, occupants may have insufficient time to protect themselves from the emergency situation. In the case of a monitored alarm system, authorities may not respond appropriately.
- This equipment, like other electrical devices, is subject to component failure. Even though this equipment is designed to last as long as 10 years, the electronic components could fail at any time.

(Continued)

**WARNING**  
**THE LIMITATIONS OF THIS ALARM SYSTEM**  
**(Continued)**

The most common cause of an alarm system not functioning when an intrusion or fire occurs is inadequate maintenance. This alarm system should be tested weekly to make sure all sensors and transmitters are working properly. The security keypad (and remote keypad) should be tested as well.

Wireless transmitters (used in some systems) are designed to provide long battery life under normal operating conditions. Longevity of batteries may be as much as 4 to 7 years, depending on the environment, usage, and the specific wireless device being used. External factors such as humidity, high or low temperatures, as well as large swings in temperature, may all reduce the actual battery life in a given installation. This wireless system, however, can identify a true low-battery situation, thus allowing time to arrange a change of battery to maintain protection for that given point within the system.

Installing an alarm system may make the owner eligible for a lower insurance rate, but an alarm system is not a substitute for insurance. Homeowners, property owners and renters should continue to act prudently in protecting themselves and continue to insure their lives and property.

We continue to develop new and improved protection devices. Users of alarm systems owe it to themselves and their loved ones to learn about these developments.

# - INDEX -

- 1**
- 1321 AC Transformer..... 1-2, 2-4
  - 1321X10..... 1-2, 2-4, 2-11, 14-2
  - 15-Second Dialer Delay (Burglary) ..4-3
- 2**
- 24-Hour Audible Alarm .....3-4
  - 24-Hour Auxiliary Alarm .....3-4
  - 24-Hour Silent Alarm.....3-4
  - 2-Wire Smoke Detectors.....2-6
- 3**
- 3-Digit Number.....9-2
- 4**
- 4204 1-2, 2-5, 2-6, 2-10, 3-1, 3-6, 6-1, 6-2, 12-2, 14-1
  - 4219, 1-1, 1-2, 2-5, 2-7, 2-10, 3-6, 14-1
  - 4229, 1-1, 1-2, 2-5, 2-6, 2-7, 2-10, 3-1, 3-6, 6-1, 6-2, 12-2, 14-1
  - 4300 Transformer.....2-4, 2-11, 14-2
  - 4-Wire Smoke Detectors.....2-7
- 5**
- 5800 Series Transmitters ..... 14-3, 14-4
  - 5800TM..... 2-9, 3-6, 14-1, 14-4, 14-5
  - 5801.....2-9
  - 5802.....2-9, 12-3
  - 5802CP.....2-9, 12-3
  - 5804 wireless key.....5-6
  - 5804BD wireless key.....2-9, 5-6
  - 5827.....2-9
  - 5827BD.....2-9
  - 5881.....1-2, 2-5, 2-9
- A**
- AAV Connections.....2-13
  - AC Power Supply.....1-2
  - AC Transformer .....2-4
  - AD12612.....2-3
  - Alarm Output..... 1-2, 2-4, 2-5
  - Alarm Sounder Timeout .....4-2
  - Alpha Descriptor .....9-2
  - Alpha Programming .....3-1
  - Alpha Vocabulary List .....9-1, 9-2
  - Arm Away/Stay Report Code.....4-5
  - Arm-Away.....3-4
  - Arming Away.....12-2
  - Arming Instant.....12-2
  - Arming Modes.....12-2
  - Arming Stay .....12-2
  - Arm-Stay .....3-4
  - Audio Alarm Verification..1-2, 2-12, 4-7
  - Authority Levels .....12-1
  - Auto-STAY Arming.....4-6
  - AUXILIARY DEVICE CURRENT DRAW WORKSHEET .....2-5
  - Auxiliary Output.....2-5
- B**
- Backup Battery.....1-2, 2-5
  - Battery Life.....2-9
  - Battery Tests.....13-3
  - Bell Supervision .....1-1
  - Bell Supervision Jumper.....2-4
  - Bypassing Zones.....12-2
- C**
- Cabinet .....2-1
  - CALIFORNIA STATE FIRE MARSHALL .....2-5
  - Caller ID Unit.....2-12
  - Cancel Report Code.....4-5
  - Cancel Verify.....4-6
  - Character (ASCII) Chart .....9-4
  - Charging Voltage .....14-1
  - Chime By Zone .....4-1
  - Chime Mode.....12-2
  - Clean Me Option .....2-6, 4-9
  - Common zone.....1-1, 3-1
  - Communication.....14-1
  - Configurable Zone Type Options...4-10
  - Configurable Zone Type Programming Fields.....4-10
  - Confirmation Of Arming Ding .....4-2
  - Contact ID Event Codes.....11-2
  - Contact ID Reporting.....14-1
  - Cross Zone Timer .....4-6
  - Custom Message.....9-3
  - Custom Words .....9-3, 9-4
- D**
- Data Field Programming Procedures3-5
  - Daylight Saving Time .....4-6
  - Defining Output Functions.....6-3
  - Descriptor Programming .....9-1
  - Device Address 2-3, 2-7, 2-10, 3-6, 4-2, 4-12, 6-1, 12-3
  - Device Duration 1, 2.....4-9
  - Dialer Communication Test .....13-3
  - Disarm .....3-4
  - Disarming.....12-2
  - Display Partition Number.....4-12
  - Double-Balanced.....2-6
  - Download Phone Number .....4-7
  - Dynamic Signaling Delay .....4-4
  - Dynamic Signaling Priority .....4-4
- E**
- Earth Ground.....2-5
  - ECP Fail Display .....4-12
  - Enrolling .....2-9, 5-1
  - Entering Serial Number.....5-5
  - Entry Delay .....3-4
  - Entry Delay 1.....4-2
  - Entry Delay 2.....4-2
  - EOLR .....2-6
  - Event Log Full Report Code .....4-6
  - Event Logging .....1-1, 4-6
  - Exit Delay.....4-2
  - Exit Error Alarm.....12-3
  - Exit Report Code .....4-4
  - Exit Time Display Interval.....4-12
  - Exit Warning.....4-2
  - Expander Module Addresses.....2-7
  - Expansion Zones .....2-7
  - Expert Programming Mode.....5-4
- F**
- FA260KP/FA560KP 1-2, 2-3, 2-5, 14-1
  - FA4285 1-1, 1-2, 2-3, 2-5, 2-12, 2-13, 4-1, 4-7, 9-3, 14-1
  - FA4286 1-1, 1-2, 2-3, 2-5, 2-12, 2-13, 3-6, 4-1, 4-7, 9-3, 14-1
  - Factory Defaults .....3-6
  - Fast Busy Signal .....2-12
  - Fault Delay Time .....4-6
  - Fire Alarm Sounder Timeout .....4-2
  - Forced Bypass Function.....4-1
  - Function Key Programming.....8-1
  - Function Keys .....3-3
- G**
- Go/No Go Test Mode .....13-2
- H**
- Handshake.....11-1
  - hardwired zones .....1-1, 2-6, 5-2, 12-3
  - HAYES Modem .....1-1
  - House ID.....2-8
- I**
- IBM Personal Computer .....3-1
  - Ideal Model 61-035.....2-5
  - Input Device Type .....5-4
  - Installer Code.....4-1
  - Interior Follower .....3-3
  - Interior w/Delay .....3-4
- K**
- Keypad Addresses .....2-3, 3-2
  - Keypad Functions .....12-2
  - Keypad Programming Fields .....4-12
  - Keyswitch.....2-9
  - Kissoff.....11-1

<b>L</b>		
Local Lockout.....	4-7	
Lock.....	2-1	
Long Range Radio, 1-2, 2-13, 3-6, 4-2, 4-4, 14-1		
Low Battery Message.....	13-3	
<b>M</b>		
Macros.....	1-1	
Master Security Code.....	4-1	
Model 112.....	2-9	
Modem.....	3-1	
Module Addresses.....	6-2	
Momentary Switch.....	2-9	
<b>N</b>		
No Alarm Response.....	3-4	
Normally Closed Zones.....	2-6	
Normally Open Zones.....	2-6	
<b>O</b>		
On-Board Triggers.....	2-11, 2-13	
Output Definition Components.....	6-3	
Output Device Mapping.....	6-1	
Output Devices.....	3-3, 6-1	
Output Functions.....	6-1	
Output relays.....	1-2	
Output To Long Range Radio.....	4-2	
<b>P</b>		
PABX Access Code.....	4-3	
Pager #1 Phone No.....	4-8	
Pager Format.....	4-8	
Pager Programming.....	3-2	
Pager Programming Fields.....	4-8	
Pager Report Options.....	4-8	
Panic Keys.....	12-3	
Part. 1 Primary Subs. Acct. No.....	4-3	
Part. 2 Primary Subs. Acct. No.....	4-3	
Partitions.....	1-1, 3-1	
Perimeter Burglary.....	3-3	
Phone Line.....	2-12	
Phone Line Monitor Enable.....	4-7	
Phone Module 1-1, 1-2, 2-3, 2-5, 2-12, 2-13, 4-1, 4-7, 9-1, 9-3, 9-4		
Phone Module Access Code.....	4-1	
Phone System Select.....	4-3	
Power Failure.....	12-4	
Power Supply.....	2-3	
Power Up In Previous State.....	4-2	
Powerline Carrier Device (X-10) House ID.....	4-1	
Powerline Carrier devices.....	2-4	
Powerline Carrier Devices 1-2, 2-11, 12-2		
Primary Phone No.....	4-3	
Prompt To Confirm.....	5-5	
<b>Q</b>		
Quick Arm Enable.....	4-1	
<b>R</b>		
Relay Module Addresses.....	2-10	
Relay Modules.....	2-10	
Report Code.....	4-4, 5-2, 5-4	
Report Code Formats.....	11-1	
Reports In Armed Period.....	4-7	
Response Time.....	2-7	
RF House ID Code.....	4-1	
RF Interference.....	2-8	
RF jam detection.....	1-1	
RF Jam Option.....	4-1	
RF Receiver.....	2-1, 2-2, 2-5, 2-8, 3-6	
Ring Detection Count.....	4-7	
RJ31X Jack.....	2-12	
<b>S</b>		
SA4120XM Cable.....	2-4	
Schedules.....	1-1, 10-1	
Secondary Phone No.....	4-3	
Security Codes.....	1-1, 12-1	
Silent Burglary.....	3-5	
Silent Panic.....	12-3	
Single Alarm Sounding Per Zone.....	4-2	
Smoke Detectors.....	2-6	
Sniffer Mode.....	13-2	
sounder connections.....	2-4	
Split/Dual Reporting.....	4-3	
Supervised Fire.....	3-4	
Supplementary Power.....	2-3	
Swinger Suppression.....	4-7	
System Communication.....	11-1	
System Operation.....	6-4	
System Status Report Codes.....	4-4	
System Test.....	13-1	
<b>T</b>		
Tamper Switch.....	2-9	
Telco Line.....	2-12	
Telephone Line Monitoring.....	1-1	
Test Mode.....	13-1	
Test Procedures.....	13-1	
Test Restore Report Code.....	4-5	
Transmitter Battery Life.....	2-9	
Transmitter Input Types.....	5-2	
Trouble Displays.....	12-3	
<b>V</b>		
VOCABULARY LIST.....	9-4	
<b>W</b>		
Wireless Key Templates.....	5-6	
Wiring Length/Gauge Chart.....	2-3	
Wiring Run Chart.....	2-3	
Word String.....	9-3	
<b>Z</b>		
Zone Doubling.....	2-6	
Zone Lists.....	3-1, 7-1	
Zone Not Used.....	3-3	
Zone Programming.....	5-1	
Zone Programming Procedure.....	5-1	
Zone Type Definitions.....	3-3	
Zone Types.....	3-3, 5-2, 6-4	



## LIMITED WARRANTY

Honeywell International Inc., Honeywell International Inc., acting through its First Alert Professional Security Systems business ("Seller"), 165 Eileen Way, Syosset, New York 11791, warrants its First Alert products to be in conformance with its own plans and specifications and to be free from defects in materials and workmanship under normal use and service for 36 months from the date stamp control on the product or, for products not having a date stamp, for 30 months from date of original purchase unless the installation instructions or catalog sets forth a shorter period, in which case the shorter period shall apply. Seller's obligation shall be limited to repairing or replacing, at its option, free of charge for materials or labor, any product which is proved not in compliance with Seller's specifications or proves defective in materials or workmanship under normal use and service. Seller shall have no obligation under this Limited Warranty or otherwise if the product is altered or improperly repaired or serviced by anyone other than First Alert Professional factory service. For warranty service, return product transportation prepaid, to: First Alert Professional Factory Service, 165 Eileen Way, Syosset, New York 11791.

THERE ARE NO WARRANTIES, EXPRESS OR IMPLIED, OF MERCHANTABILITY, OR FITNESS FOR A PARTICULAR PURPOSE OR OTHERWISE, WHICH EXTEND BEYOND THE DESCRIPTION ON THE FACE HEREOF. IN NO CASE SHALL SELLER BE LIABLE TO ANYONE FOR ANY CONSEQUENTIAL OR INCIDENTAL DAMAGES FOR BREACH OF THIS OR ANY OTHER WARRANTY, EXPRESS OR IMPLIED, OR UPON ANY OTHER BASIS OF LIABILITY WHATSOEVER, EVEN IF THE LOSS OR DAMAGE IS CAUSED BY THE SELLER'S OWN NEGLIGENCE OR FAULT.

Seller does not represent that the products it sells may not be compromised or circumvented; that the products will prevent any personal injury or property loss by burglary, robbery, fire or otherwise; or that the products will in all cases provide adequate warning or protection. Customer understands that a properly installed and maintained alarm may only reduce the risk of a burglary, robbery, fire or other events occurring without providing an alarm, but it is not insurance or a guarantee that such will not occur or that there will be no personal injury or property loss as a result. CONSEQUENTLY, SELLER SHALL HAVE NO LIABILITY FOR ANY PERSONAL INJURY, PROPERTY DAMAGE OR OTHER LOSS BASED ON A CLAIM THE PRODUCT FAILED TO GIVE WARNING. HOWEVER, IF SELLER IS HELD LIABLE, WHETHER DIRECTLY OR INDIRECTLY, FOR ANY LOSS OR DAMAGE ARISING UNDER THIS LIMITED WARRANTY OR OTHERWISE, REGARDLESS OF CAUSE OR ORIGIN, SELLER'S MAXIMUM LIABILITY SHALL NOT IN ANY CASE EXCEED THE PURCHASE PRICE OF THE PRODUCT, WHICH SHALL BE THE COMPLETE AND EXCLUSIVE REMEDY AGAINST SELLER. This warranty replaces any previous warranties and is the only warranty made by Seller on this product. No increase or alteration, written or verbal, of the obligations of this Limited Warranty is authorized



149 Eileen Way, Syosset, NY 11791  
Copyright © 2003 Honeywell International Inc.



K5305-5GPV2 9/04 Rev. A